

COMMERCIAL STOREFRONT SPACES RETROFITTED
FOR ALTERNATIVE USES AND RELATED TECHNOLOGY

CROSS-REFERENCE TO RELATED APPLICATION AND LIST OF OTHER APPLICATIONS
INCORPORATED BY REFERENCE

[0001] This claims the benefit of prior U.S. Patent Application No. 62/375,903, filed August 17, 2016, which is incorporated herein by reference in its entirety.

[0002] The following applications are also incorporated herein by reference in their entireties:

[0003] U.S. Patent Application No. 62/154,209, filed April 29, 2015, entitled "Dynamic Interstitial Hotels and Related Technology,"

[0004] U.S. Patent Application No. 62/222,750, filed September 23, 2015, entitled "School Spaces Retrofitted for Alternative Uses and Related Technology,"

[0005] U.S. Patent Application No. 62/273,700, filed December 31, 2015, entitled "Garages Retrofitted for Alternative Uses and Related Technology,"

[0006] U.S. Patent Application No. 62/310,045, filed March 18, 2016, entitled "Commercial Loading, Storage, Parking, and Vehicle-Servicing Spaces Retrofitted for Alternative Uses and Related Technology,"

[0007] U.S. Patent Application No. 15/140,785, filed April 28, 2016, entitled "Dynamic Interstitial Hotels and Related Technology,"

[0008] U.S. Patent Application No. 15/263,527, filed September 13, 2016, entitled "School Spaces Retrofitted for Alternative Uses and Related Technology,"

[0009] U.S. Patent Application No. 15/390,731, filed December 27, 2016, entitled "Garages Retrofitted for Alternative Uses and Related Technology," and

[0010] U.S. Patent Application No. 15/456,523, filed March 11, 2017, entitled "Commercial Loading, Storage, Parking, and Vehicle-Servicing Spaces Retrofitted for Alternative Uses and Related Technology."

[0011] To the extent the foregoing applications or any other material incorporated herein by reference conflicts with the present disclosure, the present disclosure controls.

TECHNICAL FIELD

[0012] This disclosure is related to real estate technology.

BACKGROUND

[0013] Building conventional real estate is capital intensive and slow. Accordingly, short-term changes in demand for real estate do not conventionally lead to rapid changes in real estate capacity. For example, markets with high demand for real estate often suffer from insufficient real estate capacity for years before new conventional real estate projects are approved and completed. Peer-to-peer real estate networks mitigate this problem to some degree, but have other significant disadvantages, such as high transaction costs, inconsistent quality, and regulatory issues. Independent of these problems, valuable real estate in major urban areas is often unutilized or under utilized. These and other aspects of conventional real estate represent inefficiencies with the potential to be at least partially addressed by innovation.

BRIEF DESCRIPTION OF THE DRAWINGS

[0014] Many aspects of the present technology can be better understood with reference to the following drawings. The relative dimensions in the drawings may be to scale with respect to some embodiments of the present technology. With respect to other embodiments, the drawings may not be to scale. For clarity of illustration, reference-number labels for analogous components or features may be omitted when the appropriate reference-number labels for such analogous components or features are clear in the context of the specification and all of the drawings considered together. Furthermore, the same reference numbers may be used to identify analogous components or features in multiple described embodiments.

[0015] Figure 1 is a front profile view of a commercial building.

[0016] Figure 2 is a cross-sectional top plan view of the commercial building shown in Figure 1 taken along the line A-A in Figure 1 with an interior space within the commercial building in a first state.

- [0017]** Figure 3 is an enlarged view of a portion of Figure 2.
- [0018]** Figure 4 is a cross-sectional top plan view of a portion of the commercial building shown in Figure 1 corresponding to the portion of Figure 2 shown in Figure 3 and showing a real estate unit in accordance with an embodiment of the present technology including the interior space within the commercial building in a second state.
- [0019]** Figure 5 is an enlarged view of a portion of Figure 4.
- [0020]** Figures 6 and 7 are, respectively, a cross-sectional exterior side profile view and a cross-sectional interior side profile view of a portion of the real estate unit shown in Figure 4 corresponding to the portion of Figure 4 shown in Figure 5.
- [0021]** Figure 8 is an enlarged view of a portion of Figure 7.
- [0022]** Figure 9 is side profile view of a wall component of the real estate unit shown in Figure 4.
- [0023]** Figure 10 is a cross-sectional top plan view of the wall component of the real estate unit shown in Figure 4 taken along the line 10-10 in Figure 9.
- [0024]** Figure 11 is a cross-sectional end profile view of the wall component of the real estate unit shown in Figure 4 taken along the line 11-11 in Figure 9.
- [0025]** Figure 12 is an enlarged view of a portion of Figure 11.
- [0026]** Figure 13 is a cross-sectional top plan view of a real estate unit in accordance with another embodiment of the present technology including the interior space within the commercial building shown in Figure 1 taken along the line 13-13 in Figure 1 with the interior space in the second state.
- [0027]** Figure 14 is an enlarged view of a portion of Figure 13.
- [0028]** Figure 15 is a cross-sectional exterior side profile view of a portion of the real estate unit shown in Figure 13 corresponding to the portion of Figure 13 shown in Figure 14.
- [0029]** Figures 16, 17, 18 and 19 are, respectively, a first side profile view, an opposite second side profile view, a first end profile view, and an opposite second end profile view of a bathroom of the real estate unit shown in Figure 4.

[0030] Figure 20 is a cross-sectional top plan view of the bathroom of the real estate unit shown in Figure 4 taken along the line 20-20 in Figure 16.

[0031] Figure 21 is an enlarged view of a portion of Figure 20.

[0032] Figure 22 is a cross-sectional bottom plan view of the bathroom of the real estate unit shown in Figure 4 taken along the line 22-22 in Figure 16.

[0033] Figure 23 is a cross-sectional top plan view of the bathroom of the real estate unit shown in Figure 4 taken along the line 23-23 in Figure 16.

[0034] Figure 24 is a cross-sectional bottom plan view of the bathroom of the real estate unit shown in Figure 4 taken along the line 24-24 in Figure 16.

[0035] Figures 25-27 are, respectively, cross-sectional top plan views of the commercial building shown in Figure 1 taken along the line A-A in Figure 1 and showing real estate units in accordance with additional embodiment of the present technology including the interior space within the commercial building in the second state.

[0036] Figures 28-30 are, respectively, cross-sectional top plan views of real estate units in accordance with additional embodiments of the present technology including the interior space within the commercial building shown in Figure 1 taken along the line A-A in Figure 1 with the interior space in the second state.

[0037] Figure 31 is a block diagram illustrating a method for making a real estate unit in accordance with an embodiment of the present technology.

[0038] Figure 32 is a block diagram illustrating a method for operating a real estate unit in accordance with an embodiment of the present technology.

DETAILED DESCRIPTION

[0039] Disclosed herein are examples of real estate units including retrofitted storefront spaces within commercial buildings and related technology. In a particular embodiment of the present technology, a real estate unit includes an interior space within a commercial building, a reusable bathroom removably disposed within the commercial building, and reusable wall components also removably disposed within the commercial building. The bathroom, the wall

components, and/or other suitable components of the real estate unit can be configured for low-cost deployment, removal, and redeployment. Use of these components can allow revenue from operating the real estate unit to exceed costs associated within transitioning the space within the commercial building from its purpose-built use (e.g., retail, office, and/or restaurant use) to an alternative use (e.g., lodging, residential, office, and/or assembly use) even if the real estate unit is only operated for a short period of time (e.g., one year or less). Thus, an operator of a network of real estate units may lease a space within a commercial building short-term (e.g., monthly) from an owner of the commercial building and retrofit the space for provision of rentable space to third parties with little or no risk of incurring significant economic loss. Even if the owner terminates the lease or if demand for the newly created real estate unit is lower than expected, most of the capital associated with retrofitting the space can be recoverable. Furthermore, capital embodied in the components can be readily relocatable in response to long-term and short-term (e.g., seasonal) changes in demand.

[0040] Among various types of real estate, commercial buildings having storefront spaces are particularly well suited to be retrofitted to accommodate alternative uses. For example, these types of spaces tend to be unfurnished or sparsely furnished in their purpose-built uses, which can facilitate retrofitting. As another example, these types of spaces typically have windows that provide abundant nature light and doors that provide direct access to outdoor areas. These features can facilitate convenient guest access and compliance with code requirements for egress. As yet another example, storefront spaces are often unused for periods of months or even years between tenancies. Unlike residential apartments, storefront space are typically leased for many years at a time. Leasing a storefront space is often a major commitment for both a tenant and a landlord, which leads to long periods of vacancy between tenancies while both sites search for the right match. During these periods of vacancy, the value of commercial spaces is typically wasted. Commercial buildings compatible with embodiments of the present technology can have other desirable attributes in addition to or instead of the forgoing attributes. Furthermore, embodiments of the present technology can be implemented in suitable other types of real estate. For example, in a warehouse or other type of commercial building having a ground-floor exterior wall that does not serve as a storefront (i.e., that does not facilitate interaction with the public), an interior space adjacent to the exterior wall can be substituted for one of the storefront spaces described herein.

[0041] Specific details of several embodiments of the present technology are disclosed herein with reference to Figures 1-32. It should be noted, in general, that other embodiments in addition to those disclosed herein are within the scope of the present technology. For example, embodiments of the present technology can have different configurations, components, and/or operations than those disclosed herein. Moreover, a person of ordinary skill in the art will understand that embodiments of the present technology can have configurations, components, and/or operations in addition to those disclosed herein and that these and other embodiments can be without configurations, components, and/or operations disclosed herein without deviating from the present technology.

[0042] Figure 1 is a back profile view of a commercial building 100 disposed between neighboring commercial buildings 101 (individually identified as neighboring commercial buildings 101a and 101b). Figure 2 is a cross-sectional top plan view of the commercial building 100 taken along the line A-A in Figure 1. With reference to Figures 1 and 2 together, the commercial building 100 can include a permanent roof 102, permanent exterior walls 104 (individually identified as exterior walls 104a-104d), and permanent interior walls 106. The exterior walls 104 can define an interior region 108 of the commercial building 100. Within the interior region 108, the commercial building 100 can include a first building bathroom 110 (e.g., a men's bathroom), a second building bathroom 112 (e.g., a women's bathroom), and a utility room 114. The commercial building 100 can further include interior doors 116 (individually identified as interior doors 116a-116c) opening into the first building bathroom 110, the second building bathroom 112, and the utility room 114, respectively.

[0043] The exterior wall 104a can be between the interior region 108 and a first outdoor area 118 that includes a sidewalk 120 and a street 122. At the exterior wall 104a, the commercial building 100 can include a storefront 124 between the interior region 108 and the first outdoor area 118. The exterior wall 104c can be between the interior region 108 and a second outdoor area 126 that includes a yard 128 and an alley 130. At the exterior wall 104c, the commercial building 100 can include a back door 132 between the interior region 108 and the second outdoor area 126. The yard 128 can be paved and/or otherwise configured to facilitate automobile parking. The commercial building 100 can include an interior space 140 at a portion of the interior region 108 nearest to the storefront 124. For simplicity of illustration, fixtures, and furnishings within the

interior space 140 are not shown. The interior space 140 can be at a ground floor of the commercial building 100. In at least some cases, the interior space 140 is a purpose-built office, retail, and/or restaurant space. In Figure 2, the interior space 140 is shown in a first state, which can be an original, pre-retrofit, or similar state. A primary egress path from the interior space 140 to the first outdoor area 118 can extend through the storefront 124.

[0044] As shown in Figure 2, the first and second building bathrooms 110, 112 can include respective toilets 142 and respective sinks 144. The commercial building 100 can include a plumbing drain trunk line 146 and a water supply trunk line 148 operably associated with the first and second building bathrooms 110, 112. The plumbing drain trunk line 146 can follow a drainage route from the first and second building bathrooms 110, 112 toward a sewage destination (e.g., a municipal sewer) (not shown). Similarly, the water supply trunk line 148 can follow a supply route from a water source (e.g., a municipal water source) (not shown) toward the first and second building bathrooms 110, 112. The plumbing drain trunk line 146 can be below-ground, such as positioned below a ground surface outside the commercial building 100 along the drainage route. In addition or alternatively, the plumbing drain trunk line 146 can be below-floor, such as positioned below a finished floor surface of the commercial building 100 along the drainage route. Similarly, the water supply trunk line 148 can be below-ground, such as positioned below a ground surface outside the commercial building 100 along the supply route. In addition or alternatively, the water supply trunk line 148 can be below-floor, such as positioned below a finished floor surface of the commercial building 100 along the supply route.

[0045] The plumbing drain trunk line 146 and/or the water supply trunk line 148 can be buried or otherwise permanently installed within a basement, a crawlspace, a chase, a foundation, a volume of dirt, or another suitable environment directly below the first and second building bathrooms 110, 112 and/or directly below an area around the first and second building bathrooms 110, 112. Furthermore, the plumbing drain trunk line 146 can be sloped to convey liquid waste (e.g., sewage) from the first and second building bathrooms 110, 112 toward the sewage destination at least partially by gravity. The water supply trunk line 148 can be configured to convey potable water from the water source to the first and second building bathrooms 110, 112 under pressure. In at least some cases, the commercial building 100 includes a building water heater 150 operably associated with the water supply trunk line 148. In these cases, the water supply trunk line 148 can

bifurcate into branches (not shown) that supply cold and hot water, respectively, to the first and second building bathrooms 110, 112, such as at the sinks 144. The building water heater 150 can be operably associated with a branch of the water supply trunk line 148 that supplies hot water to the first and second building bathrooms 110, 112. As shown in Figure 2, the building water heater 150 can be disposed within the utility room 114. The commercial building 100 can include a furnace 152 and an electrical panel 154 also disposed within the utility room 114. The commercial building 100 can further include a main electrical supply line 156 through which the electrical panel 154 is operably connected to an electrical source (e.g., a municipal power source) (not shown). Electrical lines and fixtures downstream from the electrical panel 154 are omitted for clarity of illustration. As shown in Figure 2, the commercial building 100 can include a hose bibb 160 at an exterior side of the exterior wall 104c.

[0046] Figure 3 is an enlarged view of a portion of Figure 2. Figure 4 is a cross-sectional top plan view of a portion of the commercial building 100 corresponding to the portion of Figure 2 shown in Figure 3 and showing a real estate unit 162 in accordance with an embodiment of the present technology. The real estate unit 162 can include the interior space 140 retrofitted (e.g., at least substantially reversibly retrofitted) for an alternative use. In Figure 4, the interior space 140 is shown in a second state, which can be a non-original, post-retrofit, or similar state. In the illustrated embodiment, the interior space 140 is retrofitted for lodging and/or residential use. In other embodiments, the interior space 140 can be retrofitted for another suitable alternative use, such as office, and/or assembly use in addition to or instead of lodging and/or residential use. With reference again to Figure 4, the retrofitting of the interior space 140 can occur well after (e.g., at least 20 years after) the commercial building 100 was originally constructed.

[0047] The real estate unit 162 can include a variety of retrofits (e.g., at least substantially reversible retrofits) to the commercial building 100 that change at least a portion of the commercial building 100 from being well suited a purpose-built use to being well suited for an alternative use. In at least some cases, reversal of all or a portion of these retrofits returns the portion of the commercial building 100 from being well suited for the alternative use to again being well suited for the purpose-built use. Examples of reversible retrofits include removing, installing, and relocating furniture and fixtures with little or no associated demolition of the exterior and interior walls 104, 106 or other permanent fabric of the commercial building 100. The interior space 140

and other suitable portions of the commercial building 100 can be at least substantially reversibly retrofitted to accommodate the real estate unit 162. For example, a total cost of reversible retrofits to the commercial building 100 (e.g., a present value of at least substantially reversibly installed reusable components of the real estate unit 162) for a given transformation of the interior space 140 from being well suited for a purpose-built use to being well suited for an alternative use can be greater (e.g., at least 50% greater or at least 100% greater) than a total cost of permanent retrofits to the commercial building 100 (e.g. modifications to the permanent fabric of the commercial building 100) for the given transformation. Capital associated with the alternative use can be readily re-deployable after the alternative use becomes inactive. In some cases, the alternative use and the real estate unit 162 are active for one year or less (e.g., six months or less) between successive transformations. In other cases, the alternative use and the real estate unit 162 can have longer durations or even be permanent.

[0048] As shown in Figure 4, the real estate unit 162 can include a bathroom 164 disposed (e.g., removably disposed) within the commercial building 100. The bathroom 164 can include a sink 166, a toilet 168, and a bath/shower 170. In at least some embodiments, the bathroom 164 is reusable and removably disposed within the commercial building 100. For example, unlike a conventional bathroom that can only be installed by heavy construction and removed by heavy demolition, the bathroom 164 can be configured to be installed with little or no need for heavy construction and removed with little or no need for heavy demolition. Furthermore, the bathroom 164 can be configured to be conveniently transported and reused after its removal. In the illustrated embodiment, the bathroom 164 is an assembly of reusable bathroom modules configured for rapid deployment into and removal from the commercial building 100 in an at least partially disassembled state. For example, the bathroom 164 can be made up mostly or entirely of reusable modular components. In other embodiments, a counterpart of the bathroom 164 can be portable and configured for rapid deployment into and removal from the commercial building 100 without significant disassembly. This deployment and removal can occur by forklift, by dolly, by operation of wheels integrated into the counterpart of the bathroom 164, or in another manner. In still other embodiments, a counterpart of the bathroom 164 can have other forms.

[0049] The interior space 140 can be within a compartment 186 at least partially defined by wall components 187 of the real estate unit 162. In the illustrated embodiment, the real estate unit

162 and the compartment 186 encompass no more than 60% of a total floor area of a ground floor of the commercial building 100. In other embodiments, counterparts of the real estate unit 162 and the compartment 186 can be larger, such as encompassing 60% to 80% or encompassing 60% to 100% of a total floor area of a ground floor of a counterpart of the commercial building 100. As shown in Figure 4, the wall components 187 can be disposed at a perimeter portion of the compartment 186. The wall components 187 and/or other suitable components of the compartmentalizing assembly 185 can be reusable and removably disposed within the commercial building 100. As discussed in further detail below, the wall components 187 can be stacked and/or interlocking.

[0050] In the illustrated embodiment, the real estate unit 162 is configured to be mostly off-grid (i.e., independent of service connections to local utilities). For example, the real estate unit 162 can be configured to operate at least substantially off-grid with respect to an overall electrical supply to the interior space 140, with respect to disposal of blackwater (e.g., wastewater from the toilet 168), and/or in other respects. This feature of the real estate unit 162 can be useful, for example, to avoid costs and complications associated with utility hookups, to reduce the environmental impact of the real estate unit 162, to facilitate efficient management of the real estate unit 162, to reduce costs associated with maintaining the real estate unit 162 during periods of nonuse or low use, and/or for other reasons. In other embodiments, a counterpart of the real estate unit 162 can be mostly or entirely on-grid (i.e., dependent on service connections to local utilities).

[0051] As shown in Figure 4, the real estate unit 162 can include a dock 188 disposed (e.g., removably disposed) outside the interior space 140. The dock 188 can be within the interior region 108 or outside the interior region 108. Furthermore, the dock 188 can be above-floor (as illustrated), above-ground, or below-ground (e.g., disposed within a pit). At the dock 188, the real estate unit 162 can include a heat pump 190, an exhaust filter 192, a blackwater tank 194, a water reservoir 196, a water heater 198, a greywater filter 200, a wireless router 202, a battery 204, a trash bin 206, a recycling bin 208, and a laundry bin 210. The water reservoir 196 can be operably connected to a hose bibb (not shown) and can be configured to increase a capacity of the hose bibb to supply water to the bathroom 164, such as by attenuating spikes in demand for water from the bathroom 164. In the illustrated embodiment, the real estate unit 162 is configured to separately manage removal and disposal of blackwater (e.g., wastewater from

the toilet 168) and greywater (e.g., wastewater from the sink 166 and the bath/shower 170). In other embodiments, a counterpart of the real estate unit 162 can be configured to collectively manage removal and disposal of blackwater and greywater. Accordingly, the blackwater tank 194 can be more generally referred to as a sewage tank indicating that it can be configured to receive primarily blackwater, primarily greywater, or both blackwater and greywater.

[0052] With reference again to Figure 4, the exhaust filter 192, the blackwater tank 194, the battery 204, the trash bin 206, the recycling bin 208, and the laundry bin 210 can be removably connected to the dock 188 or otherwise removably disposed outside the interior space 140. Furthermore, these components can be reusable. In the illustrated embodiment, the real estate unit 162 is configured to operate on-grid with respect to a water supply to the real estate unit 162 (e.g., because the water reservoir 196 is operably connected, for replenishment, to the water supply trunk line 148 via the hose bibb), configured to be off-grid with respect to an electrical supply to the real estate unit 162, and configured to be off-grid with respect to disposal of blackwater from the toilet 168. In other embodiments, a counterpart of the real estate unit 162 can be off-grid with respect to its water supply (e.g., because a counterpart of the water reservoir 196 is configured to be independently refilled or swapped), on-grid with respect to its electrical supply (e.g. because a counterpart of the battery 204 is operably connected, for recharging, to a counterpart of the electrical panel 154), and/or on-grid with respect its sewage disposal (e.g. because a counterpart of the blackwater tank 194 is operably connected (e.g., for draining) to a counterpart of the plumbing drain trunk line 146).

[0053] The real estate unit 162 can be configured to receive occasional servicing. This servicing can be include collecting backwater, trash, recyclables, and laundry (e.g., for cleaning and return) from the blackwater tank 194, the trash bin 206, the recycling bin 208, and the laundry bin 210, respectively. The servicing can also include recharging the battery 204. In at least some cases, the blackwater tank 194 is configured to be pumped out *in situ* and/or swapped for removal of blackwater from the real estate unit 162. Similarly, the battery 204 can be configured to be recharged *in situ* and/or swapped for at least partial replenishment of an electrical supply to the real estate unit 162. A less-full replacement for the blackwater tank 194, a more-fully-charged replacement for the battery 204, and/or other suitable replacements for components of the real estate unit 162 can be delivered to the real estate unit 162 by truck or in another manner. The replaced

components can be collected in the same or a different manner and transported to a central location (e.g., a station or substation; not shown) where the components can be efficiently processed (e.g., emptied, cleaned, recharged, etc.) for reuse. This delivery and collection can occur on a regular schedule (e.g., daily, every-other-day, etc.), as needed, and/or on demand.

[0054] As shown in Figure 4, the dock 188 can include sensors 212 (individually identified as sensors 212a-212f) operably connected to the blackwater tank 194, the water reservoir 196, the battery 204, the trash bin 206, the recycling bin 208, and the laundry bin 210, respectively. The sensors 212 can be wirelessly connected to a remote server 214 via the router 202 and a network 216 (e.g., the Internet). The server 214 can include software that automatically processes data from the sensors 212 to determine when servicing of the real estate unit 162 is required. For example, data from the sensor 212a may indicate that the blackwater tank 194 is at 75% of capacity and needs to be drained or swapped promptly. As another example, data from the sensor 212b may indicate that the water reservoir 196 is being depleted faster than it can be replenished via the hose bibb 160 and, therefore, needs to be independently replenished promptly. As yet another example, data from the sensor 212c may indicate that the battery 204 is at 25% of capacity and needs to be recharged or swapped promptly. Over time, aggregate data from the sensors 212 can be analyzed to establish default servicing intervals for the real estate unit 162. In addition or alternatively, data from the sensors 212 can be used to calculate utility usage for the real estate unit 162 for purposes of environmental reporting and/or billing a renter of the real estate unit 162. The sensors 212a-212f can be of suitable respective types for monitoring the corresponding components of the real estate unit 162. For example, the sensors 212a, 212b, 212d-212f can be weight sensors, level sensors, or other types of sensors configured to measure fullness levels of the blackwater tank 194, the water reservoir 196, the trash bin 206, the recycling bin 208, and the laundry bin 210, respectively. As another example, the sensor 212c can be a charge meter or another type of sensor configured to measure a charge of the battery 204.

[0055] The real estate unit 162 can include suitable utility lines and other connections that extend from components of the real estate unit 162 within the interior space 140 to components of the real estate unit 162 or other structures outside of the interior space 140. For example, the real estate unit 162 can include a heater/cooler 218 within the interior space 138, and the real estate unit 162 can further include refrigerant lines 220 extending between the heater/cooler 218 and the heat

pump 190. Similarly, the real estate unit 162 can include an electrical outlet 222 serving the interior space 138, and the real estate unit 162 can further include an electrical line 224 extending between the electrical outlet 222 and the battery 204. The battery 204, therefore, can be configured to power an appliance (not shown) within the interior space 138 via the electrical outlet 222 and the electrical line 224. As additional examples of suitable utility lines, the real estate unit 162 can include a blackwater drain line 226 extending between the bathroom 164 and the blackwater tank 194, a cold water supply line 228 extending between the bathroom 164 and the water reservoir 196, a hot water supply line 230 extending between the bathroom 164 and the water heater 198, a greywater drain line 232 extending between the bathroom 164 and the greywater filter 200, a plumbing ventilation line 234 extending between the bathroom 164 and the exhaust filter 192, and an exhaust line 236 also extending between the bathroom 164 and the exhaust filter 192. The blackwater drain line 226 and the greywater drain line 232 can be sloped to convey liquid waste from the bathroom 164 toward the blackwater tank 194 and the greywater filter 200, respectively, at least partially by gravity. To facilitate this sloping and/or for other reasons, the bathroom 164 can have a floor level at least 0.5 meter (e.g., at least 1 meter) higher than an underlying floor level of the interior space 138. In the illustrated embodiment, the blackwater drain line 226 and the greywater drain line 232 are separate. In other embodiments, a counterpart of the real estate unit 162 can include combined blackwater and greywater lines. Accordingly, the blackwater drain line 226 and the greywater drain line 232 can be more generally referred to as plumbing drain lines indicating that they can be configured to convey primarily blackwater, primarily greywater, or both blackwater and greywater.

[0056] The real estate unit 162 can further include a trash hatch 238, a recycling hatch 240, and a laundry hatch 242 within the interior space 138. The real estate unit 162 can also include a trash chute 244 extending between the trash hatch 238 and the trash bin 206, a recycling chute 246 extending between the recycling hatch 240 and the recycling bin 208, and a laundry chute 248 extending between the laundry hatch 242 and the laundry bin 210. The refrigerant lines 220, electrical line 224, blackwater drain line 226, cold water supply line 228, hot water supply line 230, greywater drain line 232, plumbing ventilation line 234, exhaust line 236, trash chute 244, recycling chute 246, and laundry chute 248 can extend through the wall components 187. For example, some or all of these lines and chutes can extend through openings in the wall components 187. The lines

and chutes can be removably disposed inside and/or outside the interior space 140. For example, the lines and chutes can be temporary and configured for reuse or disposal upon decommissioning of the real estate unit 162. In at least some embodiments, the blackwater drain line 226 and the greywater drain line 232 extend above-floor and then above-ground from the bathroom 164 toward the blackwater tank 194 and the greywater filter 200, respectively.

[0057] The dock 188 can include additional lines, connections, and other suitable components associated with the components of the real estate unit 162 at the dock 188. For example, the dock 188 can include a housing 250 that provides security and protection from weather to components of the real estate unit 162 at the dock 188. The housing 250 can include a lid (not shown) configured to be open when the real estate unit 162 is being serviced and closed and locked when the real estate unit 162 is not being serviced. In at least some embodiments, the lid includes solar panels (also not shown) operably connected to the battery 204. The dock 188 can further include couplings along some or all of the lines and chutes described above. These couplings can separate portions of the lines and chutes within the housing 250 from portions of the lines and chutes outside the housing 250. Thus, by operation of these couplings, the dock 188 can be transportable as a unit with little or no need to modify internal portions of the dock 188 in the field. For example, the dock 188 can be pre-manufactured with the internal components shown in Figure 4, installed at the location shown in Figure 4, and then connected up to portions of the associated lines and chutes outside of the housing 250.

[0058] The dock 188 can further include couplings that facilitate convenient removal and replacement (e.g., swapping) of the blackwater tank 194, the battery 204, the trash bin 206, the recycling bin 208, and the laundry bin 210. For example, the dock 188 can include a blackwater drain quick-connect coupling 252 through which the blackwater tank 194 is fluidically connected to the dock 188, the blackwater drain line 226, and the bathroom 164. In at least some embodiments, the blackwater drain quick-connect coupling 252 includes a check valve. Similarly, the dock 188 can include an electrical quick-connect coupling 254 through which the battery 204 is electrically connected to the dock 188, the electrical line 224, and the electrical outlet 222. The dock 188 can also include a floor 256 having pads 258 (individually identified as pads 258a-258e) that facilitate convenient registration of the blackwater tank 194, the battery 204, the trash bin 206, the recycling bin 208, and the laundry bin 210 with the blackwater drain quick-connect coupling 252, the

electrical quick-connect coupling 254, the trash chute 244, the recycling chute 246, and the laundry chute 248, respectively. For example, the pads 258a-258e can be insets in the floor 256 that snugly receive corresponding lower portions of the blackwater tank 194, the battery 204, the trash bin 206, the recycling bin 208, and the laundry bin 210, respectively.

[0059] As shown in Figure 4, the dock 188 can include a potable water inlet 260 and a greywater outlet 262. The real estate unit 162 can include a first hose 264 extending between the hose bibb 160 and the potable water inlet 260. The real estate unit 162 can further include a second hose 266 extending between the greywater outlet 262 and a greywater drain (not shown). The dock 188 can include internal plumbing (e.g., under the floor 256; not shown) fluidically connecting the water reservoir 196 and the potable water inlet 260, and fluidically connecting the greywater filter 200 and the greywater outlet 262. In at least some embodiments, this internal plumbing includes a pump (not shown). The dock 188 can further include an exhaust output fan 270 and an internal duct 272 extending between the exhaust output fan 270 and the exhaust filter 192. The dock 188 can also include an inverter 274 operably connected to the electrical line 224.

[0060] The real estate unit 162 can be furnished or otherwise outfitted with suitable furnishings, fixtures, accessories, etc. to accommodate its alternative use. In the illustrated embodiment, the real estate unit 162 is a lodging and/or residential unit with suitable furnishings, fixtures, accessories, etc. within the interior space 140 to accommodate lodging and/or residential use of the interior space 140. These furnishings, fixtures, accessories, etc. can include a bed 276, a side table 278, shelving units 280 (individually identified as shelving units 280a, 280b), a writing table 282, a chair 284, a sofa 286, a coffee table 288, a television 290, a kitchenette 292, a refrigerator 294, a set of step stairs 296, and a dining table 297. The kitchenette 292 and the set of step stairs 296 can be operably associated with the bathroom 164. The real estate unit 162 can further include a closet 298 disposed (e.g., removably disposed) within the interior space 140. The real estate unit 162 can also include a curtain 299 at an interior side of the storefront 124. The curtain 299 can be movable for privacy and to control an amount of natural light entering the interior space 140 via the storefront 124. In other embodiments, a counterpart of the real estate unit 162 can include other suitable furnishings, fixtures, accessories, etc. As described in further detail below, real estate units in accordance with other embodiments of the present technology can be rentable office units, rentable assembly units, and/or have other suitable primary uses in addition

to or instead of lodging and/or residential uses. Furthermore, rentable real estate units in accordance with embodiments of the present technology can be directly rentable, rentable via a membership system (e.g., in a member-based network of real estate units), rentable under short-term use arrangements (e.g., lodging arrangements), and/or rentable in another manner.

[0061] Figure 5 is an enlarged view of a portion of Figure 4 showing several of the wall components 187. Figures 6 and 7 are, respectively, a cross-sectional exterior (i.e., facing outward relative to the compartment 186) side profile view and a cross-sectional interior (i.e., facing inward relative to the compartment 186) side profile view of a portion of the real estate unit 162 shown in Figure 4 corresponding to the portion of Figure 4 shown in Figure 5. Figure 8 is an enlarged view of a portion of Figure 7. With reference to Figures 4-8 together, the wall components 187 can be arranged in staggered rows within a wall 448 at a perimeter portion of the interior space 140. The wall components 187 closest to the exterior wall 104b can alternate row-to-row between larger and smaller rectangular shapes. Similarly, the wall components 187 closest to the exterior wall 104d can alternate row-to-row between larger and smaller rectangular shapes. Elsewhere within the wall 448, the wall components 187 can have the larger rectangular shape. The overall wall 448 can be at least substantially self-supporting and/or at least substantially free-standing.

[0062] The interior space 140 can have a finished floor surface 450 over which the wall components 187 are removably disposed, a finished wall surface 452 beside which the wall components 187 are removably disposed, and a finished ceiling surface 454 below which the wall components 187 are removably disposed. The compartmentalizing assembly 185 can include a liner 456 disposed (e.g., removably or permanently disposed) on the finished floor surface 450 below the interior wall components 187. For example, the liner 456 can be adhesively connected to the finished floor surface 450. The liner 456 can be useful, for example, to protect the finished floor surface 450 from components of the wall 448, to facilitate layout the wall 448, to reduce or eliminate the possibility of shifting of the wall 448, and/or for other purposes. Suitable materials for the liner 456 include strips of peel-and-stick house wrap and strips of peel-and-stick roof underlayment. The liner 456 can be disposable or reusable.

[0063] In at least some embodiments, the wall 448 includes additional components that facilitate compatibility between the wall components 187 and the interior space 140 when the wall components 187 have standard dimensions and the interior space 140 has irregular dimensions. For

example, the wall 448 can include a mass of self-leveling material 458 (e.g., a disposable mass of hardened self-leveling grout) under the wall components 187 and over the liner 456. The mass of self-leveling material 458 can be molded and, in at least some cases, is integrally formed along most or all of an overall footprint of the wall 448. During formation of the mass of self-leveling material 458, the constituent self-leveling material can be of sufficiently low viscosity to level itself by gravity. Thus, the mass of self-leveling material 458 can automatically conform to slopes, dips, and other irregularities in the finished floor surface 450. When at least partially cured, the mass of self-leveling material 458 can provide the wall 448 with a reliably level surface that facilitates vertical stacking of the wall components 187.

[0064] As shown in Figures 4 and 5, the wall 448 can include compressible batting 460 disposed (e.g., stuffed) into a vertical gap between the wall components 187 and the finished wall surface 452 and disposed (e.g., stuffed) into a horizontal gap between the wall components 187 and the finished ceiling surface 454. The batting 460 can be reusable. Furthermore, the batting 460 can be non-combustible. For example, the batting 460 can be reusable bundles of lined or unlined mineral wool insulation. As shown in Figure 7, the compartmentalizing assembly 185 can include inwardly facing molding panels 462 that hide the batting 460 from inside the compartment 186. The molding panels 462 can be attached to the wall components 187 magnetically, adhesively, mechanically, or in another manner. In at least some embodiments, the overall wall 448 has a fire rating of at least two hours. This can be useful, for example, for building-code compliance when the real estate unit 162 has a use different than another ongoing use within the commercial building 100.

[0065] The individual interior wall components 187 can include downwardly extending flanges 464 that are received within successively lower wall components 187. The wall 448 can further include base blocks 466 configured to receive the flanges 464 of the interior wall components 187 within a lowest row of wall components 187 within the wall 448. When fully assembled, the wall 448 can be strong enough to support fixtures and accessories (e.g., electrical conduits, monitors, shelving, moldings, artwork, furniture supports, etc.). In at least some embodiments, exposed portions of the wall components 187 are at least partially made of ferrous metal such that fixtures and accessories can be connected to the wall 448 magnetically. In addition

or alternatively, the wall components 187 can include coupling components 468 that allow fixtures and accessories to be connected to the wall 448 mechanically and/or by gravity.

[0066] Figure 9 is side profile view of a given one of the wall components 187 separate from other portions of the wall 448. Figure 10 is a cross-sectional top plan view of the given wall component 187 taken along the line 10-10 in Figure 9. Figure 11 is a cross-sectional end profile view of the given wall component 187 taken along the line 11-11 in Figure 9. The given wall component 187 is of the large rectangular type. In at least some embodiments, other (e.g., most or all) of the wall components 187 of the large rectangular type within the wall 448 at least substantially match the given wall component 187. Furthermore, wall components 187 of the small rectangular type can have the same or similar features as the features of the given wall component 187. With reference to Figures 9-11 together, the given wall component 187 can include a shell 470 having a first side panel 472 and an opposite second side panel 474 parallel to and spaced apart from the first side panel 472. Similarly, the shell 470 can include a first end panel 476 and an opposite second end panel 478 parallel to and spaced apart from the first end panel 476. The first and second side panels 472, 474 and the first and second end panels 476, 478 can define an interior region of the given wall component 187 shaped, for example, as a rectangular solid.

[0067] The given wall component 187 can include two of the flanges 464 at the first side panel 472 and another two of the flanges 464 at the second side panel 474. As shown in Figure 11, the flanges 464 can be parallel to and inset relative to the corresponding first and second side panels 472, 474. Between the flanges 464 at the first side panel 472 and between the flanges 464 at the second side panel 474, the given wall component 187 can include respective slots 480. When the given wall component 187 is assembled with other wall components 187 of the large rectangular type within the wall 448, one of the flanges 464 at the first side panel 472 and an opposing one of the flanges 464 at the second side panel 474 can be received within the interior region of a first neighboring lower wall component 187. Similarly, the other of the flanges 464 at the first side panel 472 and the other of the flanges 464 at the second side panel 474 can be received within the interior region of a second neighboring lower wall component 187 adjacent to the first neighboring lower wall component 187. The second end panel 478 of the first neighboring lower wall component 187 and the first end panel 476 of the second neighboring lower wall component 187 can be directly adjacent to one another and received within the slots 480 of the given wall

component 187. This interaction between the wall components 187 can facilitate convenient assembly of the wall 448 with neighboring rows of the interior wall components 187 evenly staggered.

[0068] In the illustrated embodiment, the first and second side panels 472, 474 are thinner than the first and second end panels 476, 478 and made of a different material. For example, the first and second side panels 472, 474 can be metal (e.g., iron) and the first and second end panels 476, 478 can be cementitious (e.g., fiber-reinforced cement). The metal composition of the first and second side panels 472, 474 can be useful, for example, for aesthetics, to facilitate magnetic coupling of fixtures and accessories to the wall 448, and/or for other reasons. The cementitious composition of the first and second end panels 476, 478 can be useful, for example, to reduce noise transmission through the wall 448, for cost savings, and/or for other reasons. In other embodiments, the first and second side panels 472, 474 and the first and second end panels 476, 478 can have other compositions.

[0069] The given wall component 187 can further include batting 482 disposed within its interior region. Similar to the batting 460 described above, the batting 482 can be reusable and/or non-combustible. For example, the batting 482 can be reusable bundles of lined or unlined mineral wool insulation. In at least some embodiments, the batting 482 is removable. Furthermore, the shell 470 can be collapsible from an expanded state to a compact (e.g., at least partially flattened) state. For example, at corners where the first and second side panels 472, 474 and the first and second end panels 476, 478 meet, the given wall component 187 can include hinges (not shown), such as flexure bearings or piano hinges, that allow each corner to fold in a direction that causes the first and second side panels 472, 474 and the first and second end panels 476, 478 to at least partially flatten. This feature can facilitate efficient storage and transport of the shell 470 before and/or after its deployment at the real estate unit 162. When the shell 470 is collapsible, the given wall component 187 can include a rectangular inset (not shown) removably disposed within the interior of the given wall component 187 such that it rests on upper edges of the flanges 464. When present, the inset can help the given wall component 187 maintain its rectangular form during use. When the shell 470 is collapsed, the inset can be removed.

[0070] Figure 12 is an enlarged view of a portion of Figure 11. As shown in Figure 12, a lowermost portion of the first side panel 472 can overlap an uppermost portion of one of the flanges

464. Figure 12 further illustrates a given one of the coupling components 468 at the lowermost portion of the first side panel 472. In at least some embodiments, other (e.g., most or all) of the coupling components 468 of interior wall components 187 within the wall 448 at least substantially match the coupling component 468 illustrated in Figure 12. The coupling component 468 can include a notch 484 and a plug 486 removably disposed within the notch 484. The plug 486 can include a magnet 488 that releasably connects the plug 486 to the uppermost portion of the adjacent flange 464. The plug 486 can be disposed within the notch 484 when the coupling component 468 is not in use. Removing the plug 486 from the notch 484 can expose an opening into the interior of the given interior wall component 187. A mechanical fastener (e.g., a hook) (not shown) can be inserted into this opening. In this way, relatively heavy fixtures and accessories can be connected to the wall 448 through a reliable mechanical connection in addition to or instead of a magnetic connection.

[0071] Figure 13 is a cross-sectional top plan view of a real estate unit 490 in accordance with another embodiment of the present technology including the interior space 140 within the commercial building 100 taken along the line 13-13 in Figure 1 with the interior space 140 in the second state. Figure 14 is an enlarged view of a portion of Figure 13. Figure 15 is a cross-sectional exterior side profile view of a portion of the real estate unit 490 corresponding to the portion of Figure 13 shown in Figure 14. With reference to Figures 13-15 together, the real estate unit 490 can include ceiling components (e.g., reusable ceiling components) removably disposed within the commercial building 100. The ceiling components can include ceiling panels 492 and elongate ceiling beams 493 interspersed between the ceiling panels 492. The ceiling beams 493 can support the ceiling panels 492, and the wall components 187 can support the ceiling beams 493. The wall components 187 can be assembled into walls, columns, or other suitable structures that extend between the ceiling beams 493 and the finished floor surface 450. For example, the real estate unit 490 can include columns and headers (not shown) abutting an interior surface of the exterior wall 104a. The ceiling beams 493 can extend between the wall 448 and the headers. When a distance between the wall 448 and the headers does not correspond to a multiple of the length of the ceiling panels 492, and in other cases, the ceiling panels 492 and the ceiling beams 493 can be cantilevered over the wall 448.

[0072] As shown in Figure 15, the individual ceiling beams 493 can have an I-shape transverse cross-section including two channels at opposite sides of a central web. The individual ceiling panels 492 can have side edge portions snugly received within corresponding channels of adjacent ceiling beams 493. Together, the ceiling panels 492 and the ceiling beams 493 can form a ceiling 495 of the real estate unit 490. The ceiling 495 can be below an airspace 496 within the commercial building 100. The commercial building 100 can include a central heating system 497 (shown schematically) operable to heat the airspace 496 and thereby provide below-room-temperature baseline heating to the interior space 140 via the ceiling 495. The real estate unit 490 can include a supplemental heater 498 (shown schematically) operable to provide supplemental heating to the interior space 140.

[0073] With reference again to the real estate unit 162, Figures 16, 17, 18 and 19 are, respectively, a first side profile view, an opposite second side profile view, a first end profile view, and an opposite second end profile view of the bathroom 164. With reference to Figures 16-19 together, the bathroom 164 can include a rectangular floor module 500, a rectangular ceiling module 502 vertically spaced apart from the floor module 500, and a plurality of wall modules 504 (individually identified as wall modules 504a-504d) removably connected to the floor and ceiling modules 500, 502 at respective perimeter portions of the floor and ceiling modules 500, 502. The bathroom 164 can further include a lower gasket 506 disposed between the perimeter portion of the floor module 500 and the wall modules 504, and an upper gasket 508 disposed between the perimeter portion of the ceiling module 502 and the wall modules 504. The floor module 500 can include upwardly extending tabs 510 through which the floor module 500 is secured to the wall modules 504. Similarly, the ceiling module 502 can include downwardly extending tabs 512 through which the ceiling module 502 is secured to the wall modules 504. The wall modules 504c, 504d can include vertical flanges 514 at which the wall modules 504c, 504d are secured to the wall modules 504a, 504b. The bathroom 164 can include bolts 516 and associated nuts 518 at the upwardly extending tabs 510, the downwardly extending tabs 512, and the vertical flanges 514.

[0074] At the wall module 504a (Figure 18), the bathroom 164 can include a doorway opening 520, a frame 522 extending around the doorway opening 520, and a door 524 disposed within the doorway opening 520 and hingedly connected to the frame 522. The bathroom 164 can further include a handle 526 and hinges 528 operably associated with the door 524. At the wall

module 504c (Figure 16), the bathroom 164 can include a plumbing ventilation hookup 530 and an exhaust hookup 532. The plumbing ventilation hookup 530 and the exhaust hookup 532 can be configured for convenient connection to and disconnection from the plumbing ventilation line 234 and the exhaust line 236 (Figure 4), respectively, such as via quick-release couplings (not shown). The wall modules 504c, 504d can extend between the wall modules 504a, 504b at opposite sides of the bathroom 164. As discussed above, the bathroom 164 can be configured to be elevated above a floor surface of the interior space 140. For this purpose and/or another purpose, the floor module 500 can include feet 533. In at least some embodiments, a gap between the feet 533 is large enough to allow the bathroom 164, when fully assembled, to be conveniently moved by forklift. At the ceiling module 502, the bathroom 164 can include skylights 534 that allow ambient light within the interior space 138 to enter an interior of the bathroom 164.

[0075] At a side of the floor module 500 below the wall module 504c, the bathroom 164 can include a blackwater drain hookup 535, a main cold water supply hookup 536, and a main hot water supply hookup 538. At an end of the floor module 500 below the wall module 504a, the bathroom 164 can include a main electrical hookup 540 and a main greywater drain hookup 541. The blackwater drain hookup 535, the main cold water supply hookup 536, the main hot water supply hookup 538, the main electrical hookup 540, and the main greywater drain hookup 541 can be configured for convenient connection to and disconnection from the blackwater drain line 226, the cold water supply line 228, the hot water supply line 230, the electrical line 224, and the greywater drain line 232, respectively, such as via quick-release couplings (not shown). At a side of the floor module 500 below the wall module 504d, the bathroom 164 can include an auxiliary greywater drain hookup 542, an auxiliary cold water supply hookup 544, an auxiliary hot water supply hookup 546, and an auxiliary electrical hookup 548. The auxiliary greywater drain hookup 542, the auxiliary cold water supply hookup 544, the auxiliary hot water supply hookup 546, and the auxiliary electrical hookup 548 can be configured for convenient connection to and disconnection from corresponding lines (not shown) of the kitchenette 292, such as via quick-release couplings (not shown).

[0076] Figure 20 is a cross-sectional top plan view of the bathroom 164 taken along the line 20-20 in Figure 16. As shown in Figure 20, the floor module 500 can include a deck 554 on which the sink 166, the toilet 168, and the bath/shower 170 are disposed (e.g., removably disposed). The

sink 166 can include a basin 562, a sink drain 564, a sink faucet 566, a sink hot water knob 568, and a sink cold water knob 570 operably connected to one another. The toilet 168 can include a tank 572, a bowl 574, and a toilet drain 576 operably connected to one another. The bath/shower 170 can include a tub 578, a bath/shower drain 580, a tub faucet 582, a tub cold water knob 584, a tub hot water knob 586, a cold water conduit 588, and a hot water conduit 590 operably connected to one another. The cold water conduit 588 can include a riser 592 and a first branch 594 extending between the riser 592 and the tub faucet 582. The tub cold water knob 584 can be disposed along the first branch 594 and operable to control a flow of cold water from the cold water conduit 588 to the tub faucet 582. Similarly, the hot water conduit 590 can include a riser 596 and a first branch 598 extending between the riser 596 and the tub faucet 582. The tub hot water knob 586 can be disposed along the first branch 598 and operable to control a flow of hot water from the hot water conduit 590 to the tub faucet 582.

[0077] The bathroom 164 can include an electrical conduit 600, and a junction box 602 operably connected to the electrical conduit 600. The bathroom 164 can further include a first plumbing ventilation conduit 604 disposed between the sink 166 and the toilet 168, and a second plumbing ventilation conduit 605 disposed between the sink 166 and the bath/shower 170. The first and second plumbing ventilation conduits 604, 605 can be configured to ventilate blackwater and greywater plumbing, respectively. The bathroom 164 can still further include a floor drain 606 disposed between the toilet 168 and the bath/shower 170. Figure 21 is an enlarged view of a portion of Figure 20. With reference to Figures 20 and 21 together, the bathroom 164 can include vertical gaskets 608 disposed between the respective vertical flanges 514 and corresponding portions of the wall modules 504a, 504b. Similarly, the bathroom 164 can include lower tab gaskets 610 disposed between the respective upwardly extending tabs 510 and corresponding portions of the wall modules 504.

[0078] Figure 22 is a cross-sectional bottom plan view of the bathroom 164 taken along the line 22-22 in Figure 16. As shown in Figure 22, the bathroom 164 can include a light fixture 612 attached to the wall module 504c above the sink 166. The bathroom 164 can further include an exhaust intake fan 614 attached to the ceiling module 502. The electrical conduit 600 can extend from the junction box 602 (Figure 20) to the light fixture 612, and from the light fixture 612 to the exhaust intake fan 614. The first and second plumbing ventilation conduits 604, 605 can merge and

extend along an inner corner between the ceiling module 502 and the wall module 504c to the plumbing ventilation hookup 530 (Figure 16). The bathroom 164 can include an exhaust conduit 616 extending from the exhaust intake fan 614 along an inner corner between the ceiling module 502 and the wall module 504b to the exhaust hookup 532 (Figure 16). Above one end of the tub 578 (Figure 20), the bath/shower 170 (Figure 20) can include a showerhead 618, a shower cold water knob 620 operably connected to the cold water conduit 588, and a shower hot water knob 622 operably connected to the hot water conduit 590. The cold water conduit 588 can include a second branch 624 extending between the riser 592 and the showerhead 618. The shower cold water knob 620 can be disposed along the second branch 624 and operable to control a flow of cold water from the cold water conduit 588 to the showerhead 618. Similarly, the hot water conduit 590 can include a second branch 626 extending between the riser 596 and the showerhead 618. The shower hot water knob 622 can be disposed along the second branch 626 and operable to control a flow of hot water from the hot water conduit 590 to the showerhead 618. The bathroom 164 can include upper tab gaskets 628 disposed between the respective downwardly extending tabs 512 and corresponding portions of the wall modules 504.

[0079] Figure 23 is a cross-sectional top plan view of the bathroom 164 taken along the line 23-23 in Figure 16. With reference to Figures 4 and 16-23 together, the floor module 500 can include a skirt 630 and a series of parallel spaced-apart joists 632 within the skirt 630. The bathroom 164 can include a blackwater drain conduit 634 operably connected to the blackwater drain hookup 535 and the toilet drain 576. Thus, the toilet 168 can be operably connected to the blackwater tank 194 via the blackwater drain conduit 634 and the blackwater drain line 226. The blackwater drain conduit 634 can include a branch 635 operably connected to the first plumbing ventilation conduit 604. The bathroom 164 can further include a greywater drain conduit 636 operably connected to the main greywater drain hookup 541. The greywater drain conduit 636 can include branches 638 (individually identified as branches 638a-638c) operably connected to the second plumbing ventilation conduit 605, the sink drain 564, and the auxiliary greywater drain hookup 542, respectively. The greywater drain conduit 636 can further include sub-branches 639 (individually identified as sub-branches 639a, 639b) operably connected to the bath/shower drain 580 and the floor drain 606, respectively. Thus, the bath/shower drain 580 can be operably connected to the greywater filter 200 via the greywater drain conduit 636 and the greywater drain line 232. The sub-branches 639c, 639b of the greywater drain conduit 636 can include respective

traps 640. Furthermore, the blackwater drain conduit 634 and the greywater drain conduit 636 can include respective caps 642, such as to facilitate clean-out.

[0080] The bathroom 164 can include wheels 643 (e.g., swivel casters) integrated into the floor module 500. In the illustrated embodiment, the wheels 643 are embedded within the feet 533 and accessible via inwardly facing openings (not shown) of the feet 533. The individual wheels 643 can be movable between a retracted state and an extended state. For example, the bathroom 164 can include posts 644 having threads (not shown) that engage corresponding threads (not shown) of the wheels 643 such that the wheels 643 can be rotatably moved between the retracted and extended states. Moving the wheels 643 from the retracted state to the extended state can lift the bathroom 164 off a corresponding floor surface, thereby allowing the bathroom 164 to be conveniently moved along the floor surface.

[0081] The bathroom 164 can further include a main cold water conduit 645 and a main hot water conduit 646 operably connected to the main cold water supply hookup 536 and the main hot water supply hookup 538, respectively. The main cold water conduit 645 can include branches 648 (individually identified as branches 648a, 648b) operably connected to the sink 166 and the bath/shower 170 (via the riser 592), respectively. The main cold water conduit 645 can further include sub-branches 650 (individually identified as sub-branches 650a, 650b) operably connected to the auxiliary cold water supply hookup 544 and the toilet 168, respectively. The main hot water conduit 646 can include branches 652 (individually identified as branches 652a, 652b) operably connected to the sink 166 and the bath/shower 170 (via the riser 596), respectively. The main hot water conduit 646 can further include a sub-branch 654 operably connected to the auxiliary hot water supply hookup 546. The bathroom 164 can still further include a main electrical conduit 656 operably connected to the main electrical hookup 540. The main electrical conduit 656 can include branches 658 (individually identified as branches 658a, 658b) operably connected to the auxiliary electrical hookup 548 and a floor heating system (introduced below). The main electrical conduit 656 can further include a sub-branch 659 operably connected to the electrical conduit 600.

[0082] Figure 24 is a cross-sectional bottom plan view of the bathroom 164 taken along the line 24-24 in Figure 16. As shown in Figure 24, the bathroom 164 can include a floor heating system 660 operably associated with the deck 554. The floor heating system 660 can include a control box 662 operably connected to the branch 658b of the main electrical conduit 656, and a

heating cable 664 operably connected to the control box 662. The heating cable 664 can have a serpentine configuration and be directly connected to an underside of the deck 554 between the joists 632. With reference to Figures 16-24 together, the floor drain 606, the blackwater drain conduit 634 (e.g., including its branch 635), the greywater drain conduit 636 (e.g., including its branches 638 and sub-branches 639), the main cold water conduit 645 (e.g., including its branches 648 and sub-branches 650), the main hot water conduit 646 (e.g., including its branches 652 and sub-branch 654), the main electrical conduit 656 (e.g., including its branches 658 and sub-branch 659), the floor heating system 660, and/or other suitable components of the bathroom 164 can be pre-installed components of the floor module 500. Similarly, the supply plumbing for the bath/shower 170 (e.g., including the tub faucet 582, the cold water conduit 588, the hot water conduit 590, and the showerhead 618), the light fixture 612, and/or other suitable components of the bathroom 164 can be pre-installed components of the wall module 504c. These and/or other aspects of the bathroom 164 can facilitate rapid deployment, removal, and redeployment of the bathroom 164.

[0083] Figure 25 is a cross-sectional top plan view of a real estate unit 700 in accordance with another embodiment of the present technology including the interior space 140 within the commercial building 100 taken along the line A-A in Figure 1 with the interior space 140 in the second state. The real estate unit 700 can include a dock 701 that does not include the blackwater tank 194 (Figure 4) and the blackwater drain line 226 (Figure 4) of the real estate unit 162 (Figure 4). Instead of these components, the real estate unit 700 can include a blackwater drain line 702 extending between (e.g., removably disposed between) the bathroom 164 and an outdoor sewage hookup 704. The blackwater drain line 702 can extend through the exterior wall 104c from the bathroom 164 toward the sewage hookup 704. Furthermore, the blackwater drain line 702 can extend above-floor and then above-ground from the bathroom 164 toward the sewage hookup 704. The sewage hookup 704 can be a retrofitted access point to a municipal, septic, or other permanent sewage system serving the commercial building 100. In at least some cases, the blackwater drain line 702 connects to the sewage hookup 704 via a quick-connect coupling (not shown). In the illustrated embodiment, the real estate unit 700 (like the real estate unit 162 (Figure 4)) is configured to recycle greywater. In other embodiments, a counterpart of the real estate unit 700 can be configured to dispose of greywater with blackwater via the sewage hookup 704. For example, a counterpart of the bathroom 164 can be alternatively configured so that a counterpart of the

greywater drain conduit 636 (Figure 23) is combined with a counterpart of the blackwater drain conduit 634 (Figure 23).

[0084] In another embodiment, a counterpart of the real estate unit 162 (Figure 4) is operably associated with components that reduce or eliminate the need for frequent servicing and/or connections to permanent utilities serving the commercial building 100. For example, the counterpart of the real estate unit 162 (Figure 4) can be operably associated with a high-capacity sewage detention reservoir (not shown) disposed (e.g., removably disposed) outside the interior space 138, a high-capacity cold water reservoir (not shown) disposed (e.g., removably disposed) outside the interior space 138, and/or a high-capacity generator (not shown) disposed (e.g., removably disposed) outside the interior space 138. The high-capacity sewage detention reservoir can be configured for occasional evacuation into a mobile tanker (e.g., a septic system pump truck). Similarly, the high-capacity cold water reservoir can be configured for occasional replenishment from a mobile tanker (e.g., a water supply truck). In these embodiments, with reference to Figure 4, a counterpart of the dock 188 can be without the blackwater tank 194, the water reservoir 196, the greywater filter 200, and/or the battery 204.

[0085] Figure 26 is a cross-sectional top plan view of a real estate unit 710 in accordance with another embodiment of the present technology including the interior space 140 within the commercial building 100 taken along the line A-A in Figure 1 with the interior space 140 in the second state. The real estate unit 700 can include a dock 711 disposed (e.g., removably disposed) within the yard 128. The real estate unit 710 can include refrigerant lines 712, an electrical line 713, a blackwater drain line 714, a cold water supply line 715, a hot water supply line 716, and a greywater drain line 717 extending above-floor at least two meters within the commercial building 100 from the bathroom 164 toward the dock 711.

[0086] Figure 27 is a cross-sectional top plan view of a real estate unit 720 in accordance with another embodiment of the present technology including the interior space 140 within the commercial building 100 taken along the line A-A in Figure 1 with the interior space 140 in the second state. As shown in Figure 27, the real estate unit 720 can be without a dock and can, instead, be tethered to plumbing and electrical systems of the commercial building 100. The first building bathroom 110 can include a toilet hookup 722 that is exposed when the toilet 142 of the first building bathroom 110 is removed. Similarly, the first building bathroom 110 can include sink

hookups (e.g., hot and cold; not shown) that are exposed when the sink 144 of the first building bathroom 110 is disconnected. The toilet hookup 722 and the sink hookups can be operably connected to the plumbing drain trunk line 146 and the water supply trunk line 148, respectively. The real estate unit 720 can include the bathroom 164, which is operably connected to the plumbing drain trunk line 146 and the water supply trunk line 148 via the toilet hookup 722 and the sink hookups, respectively. The real estate unit 720 can further include a heat pump 726 and an exhaust filter 728 similar to the heat pump 190 and the exhaust filter 192 of the real estate unit 162.

[0087] The real estate unit 720 can further include a plumbing drain line 730 through which the bathroom 164 is operably connected to the plumbing drain trunk line 146. The plumbing drain line 730 can be disposed (e.g., removably disposed) between the bathroom 164 and the toilet hookup 722. For example, the plumbing drain line 730 can extend above-floor at least two meters within the commercial building 100 from the bathroom 164 toward the toilet hookup 722. Similarly, the real estate unit 720 can include water supply lines 732 (e.g., hot and cold) through which the bathroom 164 is operably connected to the water supply trunk line 148. The water supply lines 732 can be disposed (e.g., removably disposed) between the bathroom 164 and the sink hookups. For example, the water supply lines 732 can extend above-floor at least two meters within the commercial building 100 from the bathroom 164 toward the sink hookups. Also similarly, the real estate unit 720 can include an electrical line 734 through which the bathroom 164 and outlets (not shown) within the real estate unit 720 are operably connected to the electrical panel 154. The electrical line 734 can be disposed (e.g., removably disposed) between the bathroom 164 and the electrical panel 154. The interior doors 116a, 116b can be propped open (as shown) or removed to allow passage of the plumbing drain line 730, the water supply lines 732, and the electrical line 734 between the bathroom 164 and the toilet hookup 722, the sink hookups, and the electrical panel 154, respectively. The real estate unit 720 can further include a bridge 736 disposed over a bundle of the plumbing drain line 730, the water supply lines 732, and the electrical line 734. The bridge 736 can be reusable and removably disposed within the commercial building 100.

[0088] The real estate unit 720 can further include a sewage detention tank 738 along the plumbing drain line 730. Similarly, the real estate unit 720 can include a water supply tank (not shown) and a supplemental water heater (not shown) along the water supply lines 732. The sewage detention tank 738, the water supply tank, and the supplemental water heater can be reusable and

disposed (e.g., removably disposed) within the commercial building 100. These components can attenuate spikes in water demand and/or sewage flow from the real estate unit 720. In the illustrated embodiment, there is only one real estate unit 720 within the commercial building 100. In other embodiments, there can be multiple counterparts of the real estate unit 720 within a counterpart of the commercial building 100. In these other embodiments, a plumbing fixture load of a counterpart of the first building bathroom 110 may still be sufficient to service the multiple counterparts of the real estate unit 720 due, for example, to increased capacity provided by counterparts of the sewage detention tank 738, the water supply tank, and the supplemental water heater. In addition or alternatively, when there are two counterparts of the real estate unit 720 within a counterpart of the commercial building 100, the two counterparts of the real estate unit 720 can be separately tethered to the first and second building bathrooms 110, 112, respectively.

[0089] In the embodiments illustrated in Figures 4 and 25-27, the real estate units 162, 700, 710, 720 are configured at least primarily as lodging and/or residential units. In other embodiments, a counterpart of the real estate units 162, 700, 710, 720 can have another primary use. For example, the counterpart of the real estate units 162, 700, 710, 720 can be a rentable office unit, a rentable assembly unit, and/or a rentable unit of another type. Figure 28 is a cross-sectional top plan view of a real estate unit 750 in accordance with another embodiment of the present technology including the interior space 140 within the commercial building 100 taken along the line A-A in Figure 1 with the interior space 140 in the second state. The real estate unit 750 can be configured at least primarily as a rentable office unit. The real estate unit 750 can include office furnishings, such as a workstation 752 removably disposed within the interior space 140.

[0090] Figure 29 is a cross-sectional top plan view of a real estate unit 760 in accordance with another embodiment of the present technology including the interior space 140 within the commercial building 100 taken along the line A-A in Figure 1 with the interior space 140 in the second state. The real estate unit 760 can be configured at least primarily as a rentable assembly unit. For example, the real estate unit 760 can be configured to accommodate parties, classes, etc. The real estate unit 760 can include a dock 762 that does not include the trash bin 206 (Figure 4), the recycling bin 208 (Figure 4), and the laundry bin 210 (Figure 4) of the real estate unit 162 (Figure 4), but is otherwise the same as or similar to the dock 188 (Figure 4). Figure 30 is a cross-sectional top plan view of a real estate unit 770 in accordance with another embodiment of the

present technology including the interior space 140 within the commercial building 100 taken along the line A-A in Figure 1 with the interior space 140 in the second state. The real estate unit 770 can be configured at least primarily as a combined lodging and rentable office unit. For example, the real estate unit 770 can include partitions 772 that close off the bed 276 during work hours.

[0091] Figure 31 is a block diagram illustrating a method 900 for making a given real estate unit in accordance with an embodiment of the present technology. For simplicity, aspects of the method 900 will be further described primarily in the context of certain ones of the real estate units 162, 490, 700, 710, 720, 750, 760, 770 described herein. It should be understood, however, that the method 900, when suitable, and/or portions of the method 900, when suitable, can be practiced with respect to other ones of the real estate units 162, 490, 700, 710, 720, 750, 760, 770 described herein as well as with respect to other real estate units in accordance with embodiments of the present technology.

[0092] With reference to Figures 4-31 together, the method 900 can include leasing the interior space 140 (block 902) or establishing control of the interior space 140 in another manner. For example, the interior space 140 can be leased from an owner of the commercial building 100 for provision of lodging, residential space, office space, assembly space, and/or another type of space to third parties. In some cases, the interior space 140 is leased or purchased separately from other portions of the interior region 108. In other cases, the interior region 108 can be leased or purchased as a whole. After control of the interior space 140 is established, the method 900 can include retrofitting the interior space 140 to accommodate an alternative use (e.g., a lodging use, a residential use, an office use, and/or an assembly use). The commercial building 100 can be one that was originally constructed at least 20 years before this retrofitting occurs.

[0093] In at least some embodiments, the method 900 includes at least substantially reversibly retrofitting the interior space 140 to accommodate the alternative use. In these and other embodiments, it may be economically feasible to lease and retrofit the interior space 140 with little or no long-term commitment from an owner of the commercial building 100. This can be due to the reusability of a significant amount of the capital associated with retrofitting the interior space 140 and/or for other reasons. Accordingly, in some embodiments, the interior space 140 is leased month-to-month. In other embodiments, the interior space 140 can be leased under terms that allow the owner of the commercial building 100 to terminate the lease with notice of less than one month.

In still other embodiments, the interior space 140 can be controlled by an operator of the real estate unit 162 under other lease arrangements, under non-lease contractual arrangements (e.g., franchising), or under fee simple ownership. After direct or indirect control over the interior space 140 is established, the method 900 can include subleasing (or leasing if the commercial building 100 is owned in fee simple) the interior space 140 to a renter. When the interior space 140 is leased separately from other portions of the commercial building 100, an owner of the commercial building 100 can occupy or otherwise use the other portions of the commercial building 100 while the interior space 140 is leased to third parties. When the interior space 140 is leased together with other portions of the commercial building 100, an operator of the real estate unit 162 can separately lease the interior space 140 as the real estate unit 162 and some or all of the other portions of the commercial building 100 as another real estate unit.

[0094] The method 900 can further include transporting modules (e.g., the bathroom 164, the wall components 187, and/or the dock 188) to the commercial building 100 (block 904). Some or all of the modules can be transported in a compact state. For example, the bathroom 164 can be transported in its disassembled state. As another example, the wall components 187 can be transported in their disassembled states. Furthermore, the shells 470 can be transported in their collapsed state. The method 900 can further include receiving the modules at the commercial building 100 (block 906). For example, the bathroom 164, the wall components 187, the dock 188, and/or other suitable components of the real estate unit 162 can be received at the commercial building 100 in an at least substantially pre-manufactured state.

[0095] After the bathroom 164 is received at the commercial building 100, the method 900 can include installing the bathroom 164 (block 908), such as by disposing (e.g., removably disposing) the bathroom 164 within the commercial building 100. In at least some embodiments, installing the bathroom 164 includes assembling (e.g., at least substantially reversibly assembling) a set of reusable bathroom modules (e.g., the floor module 500, the ceiling module 502, and the wall modules 504) to form an assembly of reusable bathroom modules. For example, the method 900 can include disposing (e.g., removably disposing) the floor module 500 at a suitable location within the interior space 140, and connecting (e.g., removably connecting) the wall modules 504 to the floor module 500 at a perimeter portion of the floor module 500. The bathroom 164 can be disposed within the interior space 140 such that the floor level of the bathroom 164 is at least 0.5

meter higher than the underlying floor level of the interior space 140. The method 900 can further include installing (e.g., removably installing) furnishings within the interior space 140 (block 910). For example, when the commercial building 100 is retrofitted for lodging and/or residential use at the interior space 138, the method 900 can include disposing (e.g., removably disposing) lodging and/or residential furnishings within the interior space 140. As another example, when the commercial building 100 is retrofitted for office use at the interior space 140, the method 900 can include disposing (e.g., removably disposing) office furnishings within the interior space 140.

[0096] The method 900 can include installing the dock 188 (block 912). For example, the method 900 can include disposing (e.g., removably disposing) the dock 188 outside the interior space 140. In conjunction with installing the dock 188 or separately, the method 900 can include disposing (e.g., removably disposing) the water reservoir 196, the battery 204, the blackwater tank 194, and/or other suitable modules outside the interior space 140. These modules can be connected (e.g., removably connected) to the dock 188 and/or to other suitable components of the real estate unit 162. For example, the method 900 can include electrically connecting the battery 204 and the electrical outlet 222. This can include operating the electrical quick-connect coupling 254. As another example, the method 900 can include connecting (e.g., removably connecting) the water reservoir 196 and the hose bibb 160. In at least some embodiments, the commercial building 100 is retrofitted for off-grid operation with respect to an electrical supply to the interior space 140 and/or retrofitted for off-grid operation with respect to disposal of blackwater from the toilet 168.

[0097] The method 900 can further include tethering the bathroom 164 to the dock 188, the sewage hookup 704, the plumbing drain trunk line 146, and/or the water supply trunk line 148 (block 914). For example, the method 900 can include operably connecting the bathroom 164 (e.g., the sink 166, the toilet 168, and the bath/shower 170) and the water reservoir 196 via the cold water supply line 228. Alternatively or in addition, the method 900 can include operably connecting the bathroom 724 (e.g., the sink 166, the toilet 168, and the bath/shower 170) and the water supply trunk line 148 via the water supply lines 732 (e.g., also via the sink hookup). As another example, the method 900 can include operably connecting the bathroom 164 (e.g., the toilet 168) and the blackwater tank 194 via the blackwater drain line 226. Alternatively or in addition, the method 900 can include operably connecting the bathroom 724 (e.g., the sink 166, the toilet 168, and the bath/shower 170) and the plumbing drain trunk line 146 via the plumbing drain line 730 (e.g., also

via the toilet hookup 722). Furthermore, the method 900 can include operably connecting the bathroom 164 (e.g., the toilet 168) and the sewage hookup 704 via the blackwater drain line 702. As yet another example, the method 900 can include operably connecting the bathroom 164 (e.g., the bath/shower drain 580) and the greywater filter 200 via the greywater drain line 232.

[0098] Operably connecting the bathroom 164 and the blackwater tank 194 can include operating the blackwater drain quick-connect coupling 252 to fluidically connect the bathroom 164 and the blackwater tank 194. In addition or alternatively, operably connecting the bathroom 164 and the blackwater tank 194 can include disposing (e.g., removably disposing) the blackwater drain line 226 between the bathroom 164 and the blackwater tank 194. This can include extending the blackwater drain line 226 above-floor between the bathroom 164 and the blackwater tank 194, such as disposing a first portion of the blackwater drain line 226 above-floor within the commercial building 100 and disposing a second portion of the blackwater drain line 226 above-ground outside the commercial building 100. Similarly, operably connecting the bathroom 724 and the plumbing drain trunk line 146 can include disposing (e.g., removably disposing) the plumbing drain line 730 between the bathroom 724 and the toilet hookup 722. This can include extending the plumbing drain line 730 above-floor within the commercial building 100 between the bathroom 724 and the toilet hookup 722, such as extending the plumbing drain line 730 above-floor at least two meters within the commercial building 100 between the bathroom 724 and the toilet hookup 722. Also similarly, operably connecting the bathroom 164 and the sewage hookup 704 can include disposing (e.g., removably disposing) the blackwater drain line 702 between the bathroom 164 and the sewage hookup 704. This can include extending the blackwater drain line 702 above-floor between the bathroom 164 and the sewage hookup 704, such as disposing a first portion of the blackwater drain line 702 above-floor within the commercial building 100 and disposing a second portion of the blackwater drain line 702 above-ground outside the commercial building 100.

[0099] As shown in Figure 31, the method 900 can include installing the wall components 187 within the commercial building 100 (block 916). Installing the wall components 187 can include disposing (e.g., removably disposing) the liner 456 within the commercial building 100, such as over the finished floor surface 450. Disposing the liner 456 can include adhesively disposing the liner 456 or disposing the liner 456 in another manner. Installing the wall components 187 can further include forming the mass of self-leveling material 458 over the liner 456, such as integrally

along most or all of an overall footprint of the wall 448. After the mass of self-leveling material 458 is formed, installing the wall components 187 can include disposing (e.g., removably disposing) the wall components 187 over the mass of self-leveling material 458. Disposing the wall components 187 can include stacking and/or interlocking the wall components 187. This can be done, for example, while the shells 470 are in an expanded state. Installing the wall components 187 can further include assembling the wall components 187, such as by removably disposing the batting 460 within the shells 470 while the shells 470 are in the expanded state. In at least some embodiments, the method 900 further includes disposing (e.g., removably disposing) the ceiling panels 492, the ceiling beams 493, and/or other suitable ceiling components within the commercial building 100. For example, the ceiling panels 492 and the ceiling beams 493 can be disposed such that the ceiling beams 493 support the ceiling panels 492.

[00100] Figure 32 is a block diagram illustrating a method 950 for operating a given real estate unit in accordance with an embodiment of the present technology. As with the method 900, aspects of the method 950 will be further described primarily in the context of certain ones of the real estate units 162, 490, 700, 710, 720, 750, 760, 770 described herein. It should be understood, however, that the method 950, when suitable, and/or portions of the method 950, when suitable, can be practiced with respect to other ones of the real estate units 162, 490, 700, 710, 720, 750, 760, 770 described herein as well as with respect to other real estate units in accordance with embodiments of the present technology.

[00101] With reference to Figures 4-32 together, the method 950 can be practiced in connection with providing lodging, rentable residential space, rentable office space, rentable assembly space, and/or another type of space at the interior space 140. The method 950 can include leasing the interior space 140 (block 952) or maintaining control of the interior space 140 in another manner, such as one of the manners described above in connection with establishing control of the interior space 140 in the method 900. The method 950 can further include providing renter access to the interior space 140 (block 954), such as through the storefront 124. In this way, the method 950 can include providing renter access to furnishings at the interior space 140 corresponding to the use type. For example, the method 950 can include providing renter access to lodging and/or residential furnishings (e.g., the bed 276) within the interior space 140 when the real estate unit 162 is operated as a lodging and/or residential unit. As another example, the method 950 can include

providing renter access to office furnishings (e.g., the workstation 752) within the interior space 140 when the real estate unit 162 is operated as an office unit. Providing renter access to the interior space 140 can occur by leasing the interior space 140 to the renter, subleasing the interior space 140 to the renter, providing renter access to the interior space 140 through a membership agreement, providing renter access to the interior space 140 through a short-term use arrangement (e.g., a lodging arrangement), and/or providing renter access to the interior space 140 in another manner. Similarly, the method 950 can include providing renter access to the bathroom 164 (block 956).

[00102] The method 950 can further include flowing sewage from the bathroom 164 (block 958), such as toward the blackwater tank 194, toward the sewage hookup 704, and/or toward the plumbing drain trunk line 146. For example, the method 950 can include flowing backwater above-floor and then above-ground from the toilet 168 toward the blackwater tank 194 via the blackwater drain line 226. As another example, the method 950 can include flowing sewage (e.g., blackwater) above-floor and then above-ground from the bathroom 164 toward the sewage hookup 704 via the blackwater drain line 702 or a combined blackwater/greywater drain line. As another example, the method 950 can include flowing sewage (e.g., blackwater) above-floor at least two meters within the commercial building 100 from the bathroom 724 toward the plumbing drain trunk line 146 via the plumbing drain line 730 and via the toilet hookup 722. As yet another example, the method 950 can include flowing greywater from the bath/shower drain 580 toward the greywater filter 200 via the greywater drain line 232. Using the greywater or in another manner, the method 950 can include growing the vegetation 184 in the exterior wall components 182, such as in the planning medium 306.

[00103] The method 950 can also include swapping the blackwater tank 194 with a less full counterpart of the blackwater tank 194 to remove sewage from the real estate unit 162 (block 960). This can include operating the blackwater drain quick-connect coupling 252 to disconnect the blackwater tank 194 from fluidic connection with the bathroom 164 and removing the blackwater tank 194 from the dock 188. Swapping the blackwater tank 194 can be at least partially in response to receiving an indication of a fullness of the blackwater tank 194 from the sensor 212a. The method 950 can include weighing the blackwater tank 194 and/or determining a level of sewage within the blackwater tank 194 to determine the fullness. In addition to or instead of swapping the blackwater tank 194, the method 950 can include operating a mobile pump to at least partially pump

out the blackwater tank 194 and thereby remove sewage from the real estate unit 162. In at least some embodiments, the method 950 includes operating the real estate unit 162 at least substantially off-grid with respect to disposal of blackwater from the toilet 168.

[00104] The method 950 can further include flowing water toward the bathroom 164 (block 962). For example, the method 950 can include flowing water from the water reservoir 196 toward the bathroom 164 via the cold water supply line 228. Furthermore, the method 950 can include flowing water from the hose bibb 160 toward the water reservoir 196 to at least partially replenish a water supply to the real estate unit 162. In addition or alternatively, the method 950 can include flowing water from the water supply trunk line 148 toward the bathroom 724, such as via the water supply lines 732 and via the sink hookup. The method 950 can also include operating the heating system 497 to heat the airspace 496 and thereby provide below-room-temperature baseline heating to the interior space 138 via the ceiling 495. The method 950 can further include operating the supplemental heater 498 to provide supplemental heating to the interior space 140.

[00105] The method 950 can include providing electricity to the interior space 140 (block 964). For example, the method 950 can include using the battery 204 to power an appliance within the interior space 140 via the electrical outlet 222. The method 950 can further include swapping the battery 204 with a less depleted counterpart of the battery 204 to at least partially replenish an electrical supply to the real estate unit 162 (block 966). This can include operating the electrical quick-connect coupling 254 to disconnect the battery 204 from electrical connection with the electrical outlet 222 and removing the battery 204 from the dock 188. Swapping the battery 204 can be at least partially in response to receiving an indication of a depleted state of the battery 204 from the sensor 212c. In addition to or instead of swapping the battery 204, the method 950 can include operating a mobile recharging station to at least partially recharge the battery 204 and thereby at least partially replenish an electrical supply to the real estate unit 162. In at least some embodiments, the method 950 includes operating the real estate unit 162 at least substantially off-grid with respect to an overall electrical supply to the interior space 140. Furthermore, the method 950 can include decommissioning the real estate unit 162 after a period of operating the real estate unit 162. Decommissioning the real estate unit 162 can include suitable operations of the method 900 in reverse. For example, decommissioning the real estate unit 162 can include disassembling the wall 448 and collapsing the shells 408.

[00106] This disclosure is not intended to be exhaustive or to limit the present technology to the precise forms disclosed herein. Although specific embodiments are disclosed herein for illustrative purposes, various equivalent modifications are possible without deviating from the present technology, as those of ordinary skill in the relevant art will recognize. In some cases, well-known structures and functions have not been shown or described in detail to avoid unnecessarily obscuring the description of the embodiments of the present technology. Although steps of methods may be presented herein in a particular order, in alternative embodiments the steps may have another suitable order. Similarly, certain aspects of the present technology disclosed in the context of particular embodiments can be combined or eliminated in other embodiments. Furthermore, while advantages associated with certain embodiments may be disclosed herein in the context of those embodiments, other embodiments may also exhibit such advantages, and not all embodiments need necessarily exhibit such advantages or other advantages disclosed herein to fall within the scope of the present technology. This disclosure and the associated technology can encompass other embodiments not expressly shown or described herein.

[00107] Certain aspects of the present technology may take the form of computer-executable instructions, including routines executed by a controller or other data processor. In some embodiments, a controller or other data processor is specifically programmed, configured, or constructed to perform one or more of these computer-executable instructions. Furthermore, some aspects of the present technology may take the form of data (e.g., non-transitory data) stored or distributed on computer-readable media, including magnetic or optically readable or removable computer discs as well as media distributed electronically over networks. Accordingly, data structures and transmissions of data particular to aspects of the present technology are encompassed within the scope of the present technology. The present technology also encompasses methods of both programming computer-readable media to perform particular steps and executing the steps.

[00108] The methods disclosed herein include and encompass, in addition to methods of practicing the present technology (e.g., methods of making and operating physical embodiments of the present technology), methods of instructing others to practice the present technology. For example, a method in accordance with a particular embodiment includes providing renter access to an interior space within a compartment at least partially defined by reusable wall components removably disposed within a commercial building, and providing renter access to a reusable

bathroom removably disposed within the commercial building. A method in accordance with another embodiment includes instructing such a method.

[00109] Throughout this disclosure, the singular terms "a," "an," and "the" include plural referents unless the context clearly indicates otherwise. Similarly, unless the word "or" is expressly limited to mean only a single item exclusive from the other items in reference to a list of two or more items, then the use of "or" in such a list is to be interpreted as including (a) any single item in the list, (b) all of the items in the list, or (c) any combination of the items in the list. Additionally, the terms "comprising," "including," and the like are used throughout this disclosure to mean including at least the recited feature(s) such that any greater number of the same feature(s) and/or one or more additional types of features are not precluded. Directional terms, such as "upper," "lower," "front," "back," "vertical," and "horizontal," may be used herein to express and clarify the relationship between various structures. It should be understood that such terms do not denote absolute orientation. Furthermore, reference herein to "one embodiment," "an embodiment," or similar phrases means that a particular feature, structure, operation, or characteristic described in connection with such phrases can be included in at least one embodiment of the present technology. Thus, such phrases as used herein are not necessarily all referring to the same embodiment. Finally, it should be noted that various particular features, structures, operations, and characteristics of the embodiments described herein may be combined in any suitable manner in additional embodiments in accordance with the present technology.

CLAIMS

I claim:

1. A real estate unit, comprising:
an interior space within a commercial building, wherein the commercial building includes a storefront between the interior space and an outdoor area;
a reusable bathroom removably disposed within the commercial building; and
reusable wall components removably disposed within the commercial building, wherein the interior space is within a compartment at least partially defined by the reusable wall components.
2. The real estate unit of claim 1 wherein the interior space is a purpose-built retail, office, and/or restaurant space.
3. The real estate unit of claim 1 wherein the real estate unit is a lodging unit.
4. The real estate unit of claim 1 wherein the real estate unit is a rentable residential unit.
5. The real estate unit of claim 1 wherein the real estate unit is a rentable office unit.
6. The real estate unit of claim 1 wherein the real estate unit is a rentable assembly unit.
7. The real estate unit of claim 1 wherein:
the interior space is retrofitted for lodging and/or residential use;
the real estate unit further comprises lodging and/or residential furnishings within the interior space; and
the lodging and/or residential furnishings include a bed.

8. The real estate unit of claim 1 wherein:
the interior space is retrofitted for office use;
the real estate unit further comprises office furnishings within the interior space; and
the office furnishings include a workstation.
9. The real estate unit of claim 1 wherein the interior space is at least substantially reversibly retrofitted.
10. The real estate unit of claim 1 wherein:
the interior space is at a ground floor of the commercial building; and
the real estate unit encompasses no more than 30% of a total floor area of the ground floor.
11. The real estate unit of claim 1 wherein the reusable bathroom is portable.
12. The real estate unit of claim 1 wherein the reusable bathroom is an assembly of reusable bathroom modules.
13. The real estate unit of claim 1 wherein the reusable bathroom is made up mostly or entirely of reusable modular components.
14. The real estate unit of claim 1 wherein the reusable bathroom includes a floor module and a plurality of wall modules removably connected to the floor module at a perimeter portion of the floor module.
15. The real estate unit of claim 1 wherein the reusable bathroom has a floor level at least 0.5 meter higher than an underlying floor level of the commercial building.
16. The real estate unit of claim 1, further comprising a plumbing drain line extending between the reusable bathroom and an outdoor sewage hookup.

17. The real estate unit of claim 16 wherein the plumbing drain line is removably disposed between the reusable bathroom and the outdoor sewage hookup.

18. The real estate unit of claim 17 wherein the plumbing drain line is reusable.

19. The real estate unit of claim 16 wherein the plumbing drain line extends above-floor from the reusable bathroom toward the outdoor sewage hookup.

20. The real estate unit of claim 19 wherein the plumbing drain line extends above-floor and then above-ground from the reusable bathroom toward the outdoor sewage hookup.

21. The real estate unit of claim 1, further comprising:
a sewage tank; and
a plumbing drain line extending between the reusable bathroom and the sewage tank.

22. The real estate unit of claim 21 wherein the sewage tank is reusable.

23. The real estate unit of claim 21 wherein the plumbing drain line is removably disposed between the reusable bathroom and the sewage tank.

24. The real estate unit of claim 23 wherein the plumbing drain line is reusable.

25. The real estate unit of claim 21 wherein the plumbing drain line extends above-floor from the reusable bathroom toward the sewage tank.

26. The real estate unit of claim 25 wherein the plumbing drain line extends above-floor and then above-ground from the reusable bathroom toward the sewage tank.

27. The real estate unit of claim 21 wherein:
the plumbing drain line is a blackwater drain line;

the real estate unit further comprises—

a greywater filter, and

a greywater drain line extending between the reusable bathroom and the greywater filter; and

the reusable bathroom includes—

a toilet operably connected to the sewage tank via the blackwater drain line, and

a shower drain operably connected to the greywater filter via the greywater drain line.

28. The real estate unit of claim 21 wherein the sewage tank is configured to be pumped out for removal of sewage from the real estate unit.

29. The real estate unit of claim 21 wherein the sewage tank is removably disposed outside the interior space.

30. The real estate unit of claim 29 wherein the sewage tank is configured to be swapped for removal of sewage from the real estate unit.

31. The real estate unit of claim 30, further comprising a dock disposed outside the interior space, wherein the sewage tank is removably connected to the dock.

32. The real estate unit of claim 31 wherein the dock is removably disposed outside the interior space.

33. The real estate unit of claim 31 wherein:

the dock includes a plumbing drain quick-connect coupling; and

the sewage tank is fluidically connected to the dock via the plumbing drain quick-connect coupling.

34. The real estate unit of claim 31 wherein:

the dock includes a sensor operably connected to the sewage tank; and

the sensor is configured to measure a fullness of the sewage tank.

35. The real estate unit of claim 34 wherein the sensor is a weight sensor.

36. The real estate unit of claim 34 wherein the sensor is a level sensor.

37. The real estate unit of claim 1, further comprising:

a water reservoir; and

a water supply line extending between the reusable bathroom and the water reservoir.

38. The real estate unit of claim 37 wherein the water reservoir is removably disposed outside the interior space.

39. The real estate unit of claim 37 wherein:

the commercial building includes a hose bibb; and

the water reservoir is operably connected to the hose bibb.

40. The real estate unit of claim 1, further comprising:

an electrical outlet serving the interior space; and

a battery configured to power an appliance within the interior space via the electrical outlet.

41. The real estate unit of claim 40 wherein the battery is removably disposed outside the interior space.

42. The real estate unit of claim 41 wherein the battery is configured to be swapped for at least partial replenishment of an electrical supply to the real estate unit.

43. The real estate unit of claim 42, further comprising a dock disposed outside the interior space, wherein the battery is removably connected to the dock.

44. The real estate unit of claim 43 wherein the dock is removably disposed outside the interior space.

45. The real estate unit of claim 43 wherein:
the dock includes an electrical quick-connect coupling; and
the battery is electrically connected to the dock via the electrical quick-connect coupling.

46. The real estate unit of claim 40 wherein the battery is configured to be recharged for at least partial replenishment of an electrical supply to the real estate unit.

47. The real estate unit of claim 1 wherein the real estate unit is configured to operate at least substantially off-grid with respect to an overall electrical supply to the interior space.

48. The real estate unit of claim 47 wherein:
the reusable bathroom includes a toilet; and
the real estate unit is configured to operate at least substantially off-grid with respect to disposal of blackwater from the toilet.

49. The real estate unit of claim 1, wherein:
the commercial building includes a plumbing drain trunk line; and
the real estate unit further comprises a plumbing drain line through which the reusable bathroom is operably connected to the plumbing drain trunk line.

50. The real estate unit of claim 49, wherein:
the commercial building includes a building bathroom having a toilet hookup operably connected to the plumbing drain trunk line; and
the reusable bathroom is operably connected to the plumbing drain trunk line via the toilet hookup.

51. The real estate unit of claim 50 wherein the plumbing drain line is removably disposed between the reusable bathroom and the toilet hookup.

52. The real estate unit of claim 51 wherein the plumbing drain line is reusable.
53. The real estate unit of claim 50 wherein the plumbing drain line extends above-floor at least two meters within the commercial building from the reusable bathroom toward the toilet hookup.
54. The real estate unit of claim 1, wherein:
the commercial building includes a water supply trunk line; and
the real estate unit further comprises a water supply line through which the reusable bathroom is operably connected to the water supply trunk line.
55. The real estate unit of claim 54, wherein:
the commercial building includes a building bathroom having a sink hookup operably connected to the water supply trunk line; and
the reusable bathroom is operably connected to the water supply trunk line via the sink hookup.
56. The real estate unit of claim 1 wherein:
the interior space has a finished floor; and
the reusable wall components are removably disposed over the finished floor.
57. The real estate unit of claim 1 wherein the reusable wall components are stacked.
58. The real estate unit of claim 1 wherein the reusable wall components are interlocking.
59. The real estate unit of claim 1, further comprising an at least substantially self-supporting wall at a perimeter portion of the interior space, wherein the wall includes the reusable wall components.

60. The real estate unit of claim 1, further comprising an at least substantially free-standing wall at a perimeter portion of the interior space, wherein the wall includes the reusable wall components.

61. The real estate unit of claim 1, further comprising a wall at a perimeter portion of the interior space, wherein the wall includes the reusable wall components, and wherein the wall has a fire rating of at least two hours.

62. The real estate unit of claim 1, further comprising a wall at a perimeter portion of the interior space, wherein the wall includes the reusable wall components, and wherein the wall is made up mostly or entirely of reusable modular components.

63. The real estate unit of claim 1 wherein:
the reusable wall components individually include a rigid shell and a package removably disposed within the shell; and
the package includes insulation.

64. The real estate unit of claim 63 wherein the shell is collapsible.

65. The real estate unit of claim 1, further comprising reusable ceiling components removably disposed within the commercial building, wherein the compartment is at least partially defined by the reusable wall components and the reusable ceiling components.

66. The real estate unit of claim 65 wherein the reusable ceiling components include rigid ceiling panels and elongate ceiling beams supporting the rigid ceiling panels.

67. The real estate unit of claim 1, further comprising a wall at a perimeter portion of the interior space, wherein the wall includes the reusable wall components, and wherein the wall includes a mass of molded self-leveling material underlying the reusable wall components.

68. The real estate unit of claim 67 wherein the mass of molded self-leveling material is integrally formed along most or all of an overall footprint of the wall.

69. The real estate unit of claim 67 wherein the wall includes a liner underlying the mass of molded self-leveling material.

70. The real estate unit of claim 69 wherein:
the interior space has a finished floor; and
the liner is removably connected to the finished floor.

71. The real estate unit of claim 69 wherein:
the interior space has a finished floor; and
the liner is adhesively connected to the finished floor.

72. The real estate unit of claim 1 wherein:
the commercial building includes a central heating system;
the real estate unit includes a ceiling below an airspace within the commercial building;
the central heating system is operable to heat the airspace and thereby provide below-room-temperature baseline heating to the interior space via the ceiling; and
the real estate unit includes a supplemental heater operable to provide supplemental heating to the interior space.

73. A method for operating a real estate unit, the method comprising:
providing renter access to an interior space within a compartment at least partially defined by reusable wall components removably disposed within a commercial building, wherein the commercial building includes a storefront between the interior space and an outdoor area, and wherein providing renter access to the interior space includes providing renter access to the interior space via the storefront; and
providing renter access to a reusable bathroom removably disposed within the commercial building.

74. The method of claim 73, further comprising providing lodging at the real estate unit.
75. The method of claim 73, further comprising providing rentable residential space at the real estate unit.
76. The method of claim 73, further comprising providing rentable office space at the real estate unit.
77. The method of claim 73, further comprising providing rentable assembly space at the real estate unit.
78. The method of claim 73, further comprising providing renter access to lodging and/or residential furnishings within the interior space, wherein the lodging and/or residential furnishings include a bed.
79. The method of claim 73, further comprising providing renter access to office furnishings within the interior space, wherein the office furnishings include a workstation.
80. The method of claim 73, further comprising:
leasing the interior space from an owner of the commercial building; and
subleasing the interior space to a renter of the real estate unit.
81. The method of claim 80 wherein leasing the interior space includes leasing the interior space for provision of lodging, residential space, office space, and/or assembly space.
82. The method of claim 80 wherein leasing the interior space includes leasing the interior space month-to-month.

83. The method of claim 80 wherein leasing the interior space includes leasing the interior space under a lease having terms that allow the owner to terminate the lease with notice of less than one month.

84. The method of claim 73 further comprising flowing sewage from the reusable bathroom toward an outdoor sewage hookup via a plumbing drain line of the real estate unit.

85. The method of claim 84 wherein flowing the sewage includes flowing the sewage above-floor.

86. The method of claim 85 wherein flowing the sewage includes flowing the sewage above-floor and then above-ground.

87. The method of claim 73 further comprising flowing sewage from the reusable bathroom toward a sewage tank of the real estate unit via a plumbing drain line of the real estate unit.

88. The method of claim 87 wherein flowing the sewage includes flowing the sewage above-floor.

89. The method of claim 88 wherein flowing the sewage includes flowing the sewage above-floor and then above-ground.

90. The method of claim 87 wherein:
the sewage is blackwater;
the plumbing drain line is a blackwater drain line;
flowing the blackwater includes flowing the blackwater from a toilet of the reusable bathroom toward the sewage tank via the blackwater drain line; and
the method further comprises flowing greywater from a shower drain of the reusable bathroom toward a greywater filter of the real estate unit via a greywater drain line of the real estate unit.

91. The method of claim 87, further comprising operating a mobile pump to at least partially pump out the sewage tank and thereby remove sewage from the real estate unit.

92. The method of claim 87, further comprising swapping the sewage tank with a less full sewage tank to remove sewage from the real estate unit.

93. The method of claim 92 wherein:
the real estate unit further comprises a dock disposed outside the interior space; and
swapping the sewage tank includes removing the sewage tank from the dock.

94. The method of claim 93 wherein swapping the sewage tank includes operating a plumbing drain quick-connect coupling of the dock to disconnect the sewage tank from fluidic connection with the reusable bathroom.

95. The method of claim 93, further comprising receiving an indication of a fullness of the sewage tank from a sensor of the dock.

96. The method of claim 95 wherein:
the sensor is a weight sensor; and
wherein the method further comprises weighing the sewage tank to determine the fullness.

97. The method of claim 95 wherein:
the sensor is a level sensor; and
the method further comprises determining a level of sewage within the sewage tank to determine the fullness.

98. The method of claim 73, further comprising flowing water from a water reservoir of the real estate unit toward the reusable bathroom via a water supply line of the real estate unit.

99. The method of claim 98, further comprising flowing water from a hose bibb of the commercial building toward the water reservoir to at least partially replenish a water supply to the real estate unit.

100. The method of claim 73 wherein:
the real estate unit includes a battery; and
the method further comprises using the battery to power an appliance within the interior space via an electrical outlet of the real estate unit.

101. The method of claim 100, further comprising swapping the battery with a less depleted battery to at least partially replenish an electrical supply to the real estate unit.

102. The method of claim 101 wherein:
the real estate unit further comprises a dock disposed outside the interior space; and
swapping the battery includes removing the battery from the dock.

103. The method of claim 102 wherein swapping the battery includes operating an electrical quick-connect coupling of the dock to disconnect the battery from electrical connection with the outlet.

104. The method of claim 100, further comprising operating a mobile recharging station to at least partially recharge the battery and thereby at least partially replenish an electrical supply to the real estate unit.

105. The method of claim 73, further comprising operating the real estate unit at least substantially off-grid with respect to an overall electrical supply to the interior space.

106. The method of claim 105, further comprising operating the real estate unit at least substantially off-grid with respect to disposal of blackwater from a toilet of the reusable bathroom.

107. The method of claim 73, further comprising flowing waste from the reusable bathroom toward a plumbing drain trunk line of the commercial building via a plumbing drain line of the real estate unit.

108. The method of claim 107, wherein:
the commercial building includes a building bathroom having a toilet hookup operably connected to the plumbing drain trunk line; and
flowing waste from the reusable bathroom toward the plumbing drain trunk line includes flowing waste from the reusable bathroom toward the plumbing drain trunk line via the toilet hookup.

109. The method of claim 107 wherein flowing waste from the reusable bathroom toward the plumbing drain trunk line includes flowing waste above-floor at least two meters within the commercial building.

110. The method of claim 73, further comprising flowing water from a water supply trunk line of the commercial building toward the reusable bathroom via a water supply line of the real estate unit.

111. The method of claim 110, wherein:
the commercial building includes a building bathroom having a sink hookup operably connected to the water supply trunk line; and
flowing water from the water supply trunk line toward the reusable bathroom includes flowing water from the water supply trunk line toward the reusable bathroom via the sink hookup.

112. The method of claim 73 wherein:
the real estate unit further comprises a compartmentalizing assembly including—
reusable wall components removably disposed within the commercial building, and
a ceiling below an airspace within the commercial building;

the interior space is within a compartment at least partially defined by the compartmentalizing assembly; and

the method further comprises—

operating a central heating system of the commercial building to heat the airspace and thereby provide below-room-temperature baseline heating to the interior space via the ceiling, and

operating a supplemental heater of the real estate unit to provide supplemental heating to the interior space.

113. A method for making a real estate unit, the method comprising:
retrofitting a purpose-built retail, office, and/or restaurant space within a commercial building for an alternative use, wherein the commercial building includes a storefront between the space and an outdoor area;
removably disposing a reusable bathroom within the commercial building; and
removably disposing reusable wall components within the commercial building to form a wall at a perimeter portion of the space.

114. The method of claim 113 wherein retrofitting the space includes retrofitting the space for lodging use.

115. The method of claim 113 wherein retrofitting the space includes retrofitting the space for residential use.

116. The method of claim 113 wherein retrofitting the space includes retrofitting the space for office use.

117. The method of claim 113 wherein retrofitting the space includes retrofitting the space for assembly use.

118. The method of claim 113, further comprising disposing lodging and/or residential furnishings within the space, wherein the lodging and/or residential furnishings include a bed.

119. The method of claim 113, further comprising disposing office furnishings within the space, wherein the office furnishings include a workstation.

120. The method of claim 113 wherein retrofitting the space includes at least substantially reversibly retrofitting the space.

121. The method of claim 113 wherein retrofitting the space includes retrofitting the space at least 20 years after the commercial building was originally constructed.

122. The method of claim 113, further comprising transporting the reusable bathroom to the commercial building in a disassembled state.

123. The method of claim 113, further comprising receiving the reusable bathroom at the commercial building in an at least substantially pre-manufactured state.

124. The method of claim 113, further comprising at least substantially reversibly assembling reusable bathroom modules to form the reusable bathroom.

125. The method of claim 113, further comprising removably connecting a plurality of wall modules of the reusable bathroom to a floor module of the reusable bathroom at a perimeter portion of the floor module.

126. The method of claim 113 wherein removably disposing the reusable bathroom includes removably disposing the reusable bathroom such that a floor level of the reusable bathroom is at least 0.5 meter higher than an underlying floor level of the space.

127. The method of claim 113, further comprising operably connecting the reusable bathroom and an outdoor sewage hookup via a plumbing drain line of the real estate unit.

128. The method of claim 127 wherein operably connecting the reusable bathroom and the outdoor sewage hookup includes removably disposing the plumbing drain line between the reusable bathroom and the outdoor sewage hookup.

129. The method of claim 127 wherein operably connecting the reusable bathroom and the outdoor sewage hookup includes extending the plumbing drain line above-floor between the reusable bathroom and the outdoor sewage hookup.

130. The method of claim 127 wherein operably connecting the reusable bathroom and the outdoor sewage hookup includes:

- disposing a first portion of the plumbing drain line above-floor within the commercial building; and
- disposing a second portion of the plumbing drain line above-ground outside the commercial building.

131. The method of claim 113 further comprising operably connecting the reusable bathroom and a sewage tank of the real estate unit via a plumbing drain line of the real estate unit.

132. The method of claim 131 wherein operably connecting the reusable bathroom and the sewage tank includes removably disposing the plumbing drain line between the reusable bathroom and the sewage tank.

133. The method of claim 131 wherein operably connecting the reusable bathroom and the sewage tank includes extending the plumbing drain line above-floor between the reusable bathroom and the sewage tank.

134. The method of claim 131 wherein operably connecting the reusable bathroom and the sewage tank includes:

- disposing a first portion of the plumbing drain line above-floor within the commercial building; and

disposing a second portion of the plumbing drain line above-ground outside the commercial building.

135. The method of claim 131 wherein:

the plumbing drain line is a blackwater drain line;

the reusable bathroom includes a toilet and a shower drain;

operably connecting the reusable bathroom and the sewage tank includes operably connecting the toilet and the sewage tank via the blackwater drain line; and

the method further comprises operably connecting the shower drain and a greywater filter of the real estate unit via a greywater drain line of the real estate unit.

136. The method of claim 131, further comprising removably disposing the sewage tank outside the space.

137. The method of claim 136, further comprising:

disposing a dock outside the space; and

removably connecting the sewage tank to the dock.

138. The method of claim 137 wherein disposing the dock includes removably disposing the dock.

139. The method of claim 137 wherein removably connecting the sewage tank to the dock includes operating a plumbing drain quick-connect coupling of the dock to fluidically connect the sewage tank and the reusable bathroom.

140. The method of claim 113 further comprising operably connecting the reusable bathroom and a water reservoir of the real estate unit via a water supply line of the real estate unit.

141. The method of claim 140 further comprising removably disposing the water reservoir outside the space.

142. The method of claim 140 further comprising removably connecting the water reservoir and a hose bibb of the commercial building.

143. The method of claim 113, further comprising disposing a battery outside the space, wherein the battery is configured to power an appliance within the space via an electrical outlet of the real estate unit.

144. The method of claim 143 wherein disposing the battery includes removably disposing the battery.

145. The method of claim 144, further comprising:
disposing a dock outside the space; and
removably connecting the battery to the dock.

146. The method of claim 145 wherein disposing the dock includes removably disposing the dock.

147. The method of claim 145 wherein removably connecting the battery to the dock includes operating an electrical quick-connect coupling of the dock to electrically connect the battery and the electrical outlet.

148. The method of claim 113, further comprising operably connecting the reusable bathroom and a plumbing drain trunk line of the commercial building via a plumbing drain line of the real estate unit.

149. The method of claim 148, wherein:
the commercial building includes a building bathroom having a toilet hookup operably connected to the plumbing drain trunk line; and
operably connecting the reusable bathroom and the plumbing drain trunk line includes operably connecting the reusable bathroom and the plumbing drain trunk line via the toilet hookup.

150. The method of claim 149 wherein operably connecting the reusable bathroom and the plumbing drain trunk line includes removably disposing the plumbing drain line between the reusable bathroom and the toilet hookup.

151. The method of claim 149 wherein operably connecting the reusable bathroom and the plumbing drain trunk line includes extending the plumbing drain line above-floor at least two meters within the commercial building from the reusable bathroom toward the toilet hookup.

152. The method of claim 113, further comprising operably connecting the reusable bathroom and a water supply trunk line of the commercial building via a water supply line of the real estate unit.

153. The method of claim 152, wherein:
the commercial building includes a building bathroom having a sink hookup operably connected to the water supply trunk line; and
operably connecting the reusable bathroom and the water supply trunk line includes operably connecting the reusable bathroom and the water supply trunk line via the sink hookup.

154. The method of claim 113 wherein removably disposing the reusable wall components includes removably disposing the reusable wall components over a finished floor of the space.

155. The method of claim 113 wherein removably disposing the reusable wall components includes stacking the reusable wall components.

156. The method of claim 113 wherein removably disposing the reusable wall components includes interlocking the reusable wall components.

157. The method of claim 113, further comprising assembling the reusable wall components, wherein assembling a given one of the reusable wall components includes removably disposing a package of insulation within a rigid shell.

158. The method of claim 113, further comprising transporting rigid shells of the reusable wall components to the commercial building while the shells are in a collapsed state, wherein removably disposing the reusable wall components includes removably disposing the reusable wall components while the shells are in an expanded state.

159. The method of claim 113, further comprising removably disposing reusable ceiling components within the commercial building to form a ceiling above the space.

160. The method of claim 159 wherein removably disposing the reusable ceiling components includes removably disposing rigid ceiling panels and elongate ceiling beams such that the elongate ceiling beams support the ceiling panels.

161. The method of claim 113, further comprising forming a mass of molded self-leveling material within the commercial building, wherein removably disposing the reusable wall components includes removably disposing the reusable wall components over the mass of molded self-leveling material.

162. The method of claim 161 wherein forming the mass of molded self-leveling material includes forming the mass of molded self-leveling material integrally along most or all of an overall footprint of the wall.

163. The method of claim 161, further comprising disposing a liner over a finished floor of the space, wherein forming the mass of molded self-leveling material includes forming the mass of molded self-leveling material over the liner.

164. The method of claim 163 wherein disposing the liner includes removably disposing the liner.

165. The method of claim 163 wherein disposing the liner includes adhesively connecting the liner to the finished floor.

166. A real estate unit comprising any non-conflicting combination of claims 1-72.

167. A method for operating a real estate unit, the method comprising any non-conflicting combination of claims 73-112.

168. A method for making a real estate unit, the method comprising any non-conflicting combination of claims 113-165.

169. A real estate unit, comprising:

a first interior space within a commercial building, wherein the commercial building includes a storefront between the first interior space and an outdoor area;

a bathroom means for providing private showering and toilet accommodations to a renter of the real estate unit; and

a wall means for separating the first interior space from a second interior space within the commercial building.

170. The real estate unit of claim 169, further comprising blackwater disposal means for disposing of blackwater from the bathroom means.

171. The real estate unit of claim 169, further comprising greywater recycling means for recycling greywater from the bathroom means.

172. The real estate unit of claim 169, further comprising electricity supplying means for supplying electricity to the real estate unit.

ABSTRACT

A real estate unit in accordance with a particular embodiment of the present technology includes an interior space within a commercial building, and a reusable bathroom removably disposed within the commercial building. The commercial building can include a storefront between the interior space and an outdoor area. The real estate unit can further include reusable wall components removably disposed within the commercial building. For example, the interior space can be within a compartment at least partially defined by the reusable wall components. In at least some cases, the interior space is a purpose-built retail, office, and/or restaurant space. The real estate unit can be a lodging unit, a rentable residential unit, a rentable office unit, and/or a rentable assembly unit.

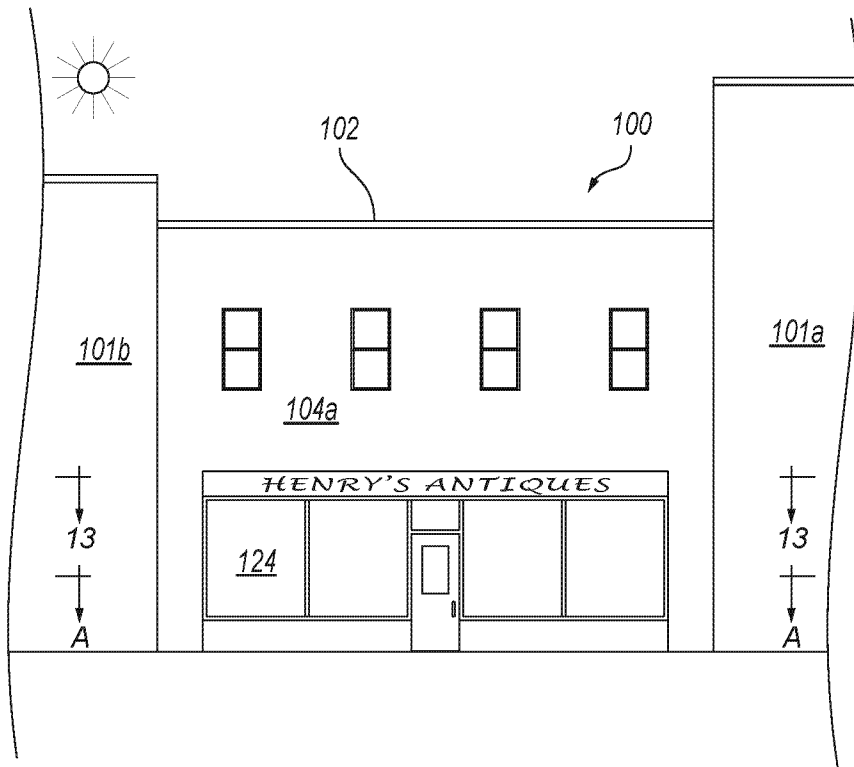

Fig. 1 (prior art)

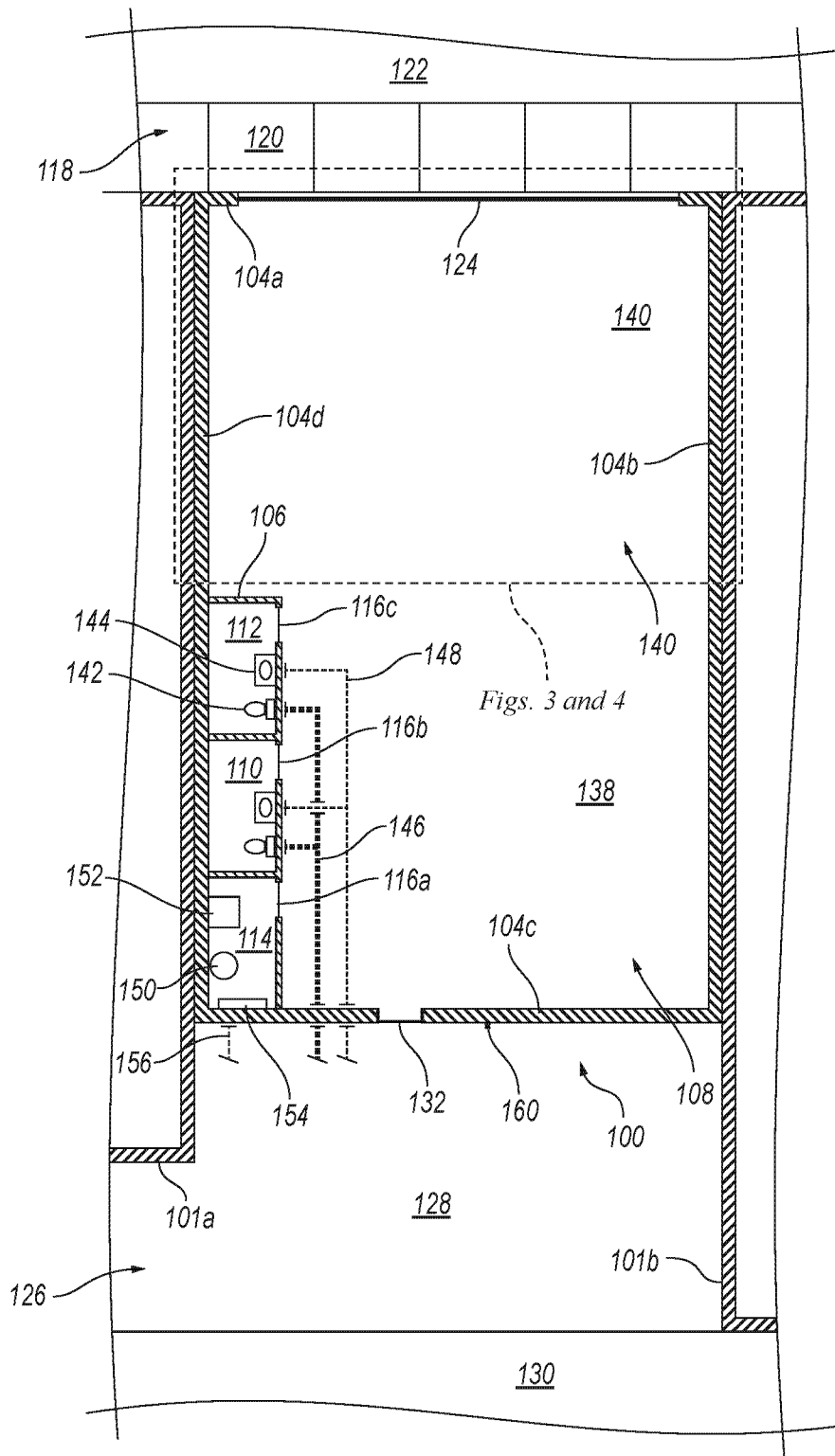

Fig. 2 (prior art)

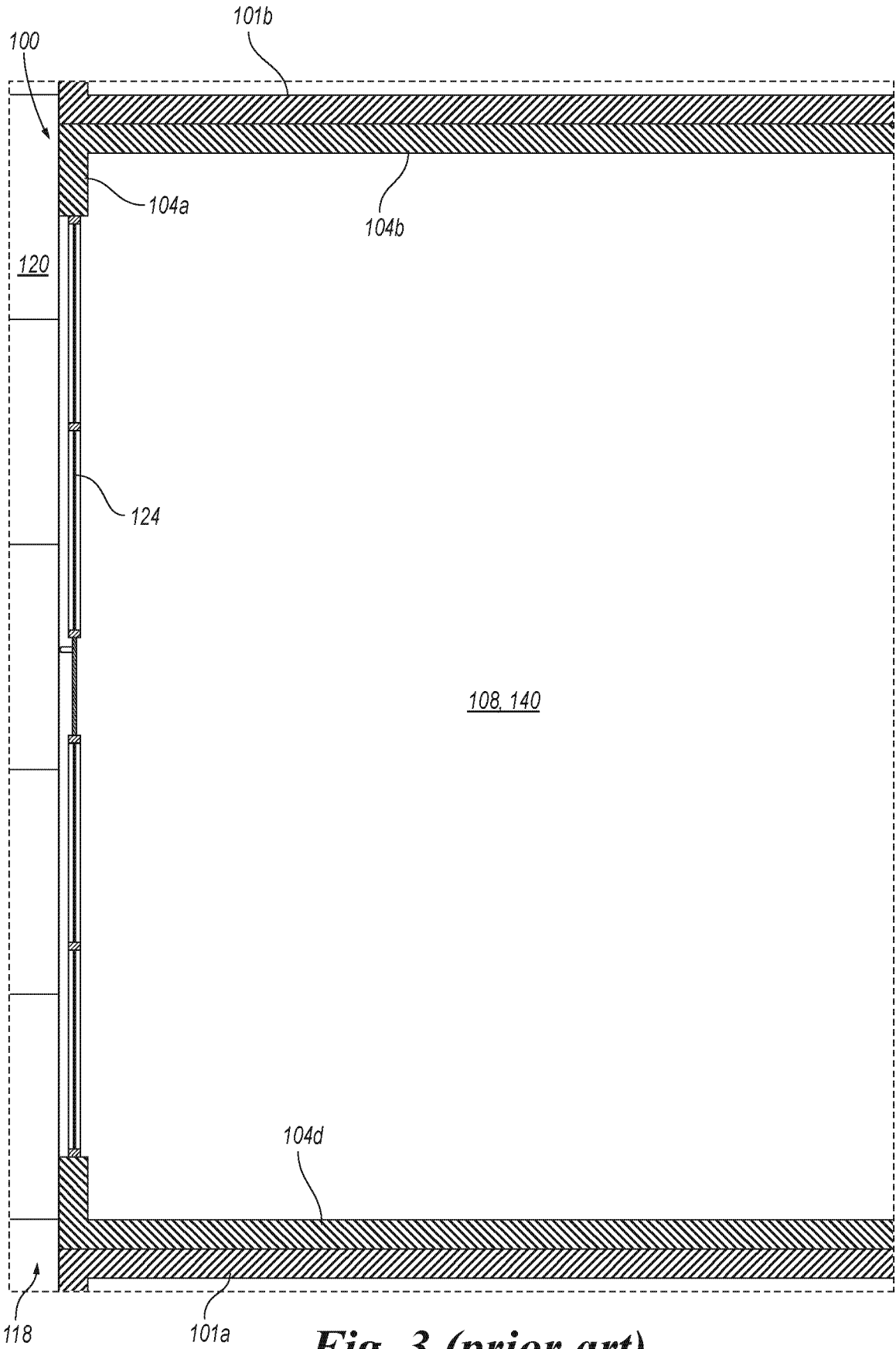

Fig. 3 (prior art)

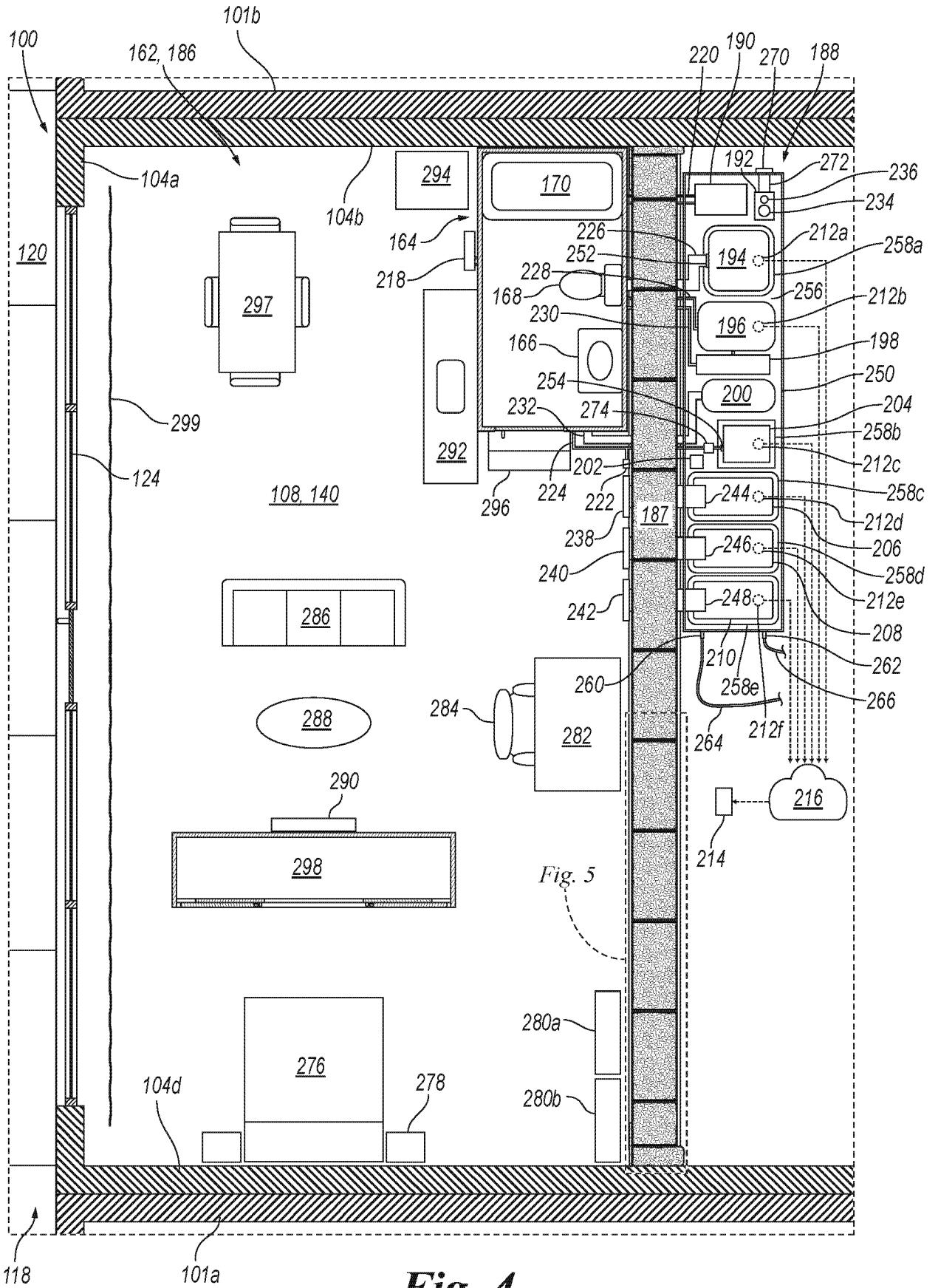

Fig. 4

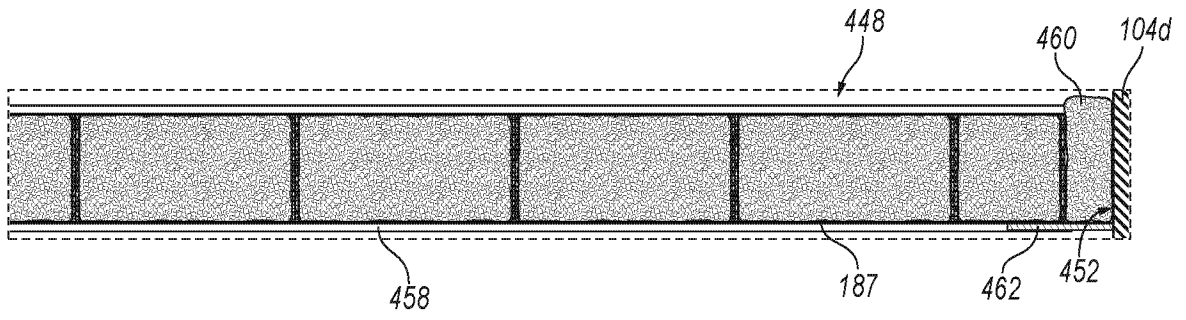

Fig. 5

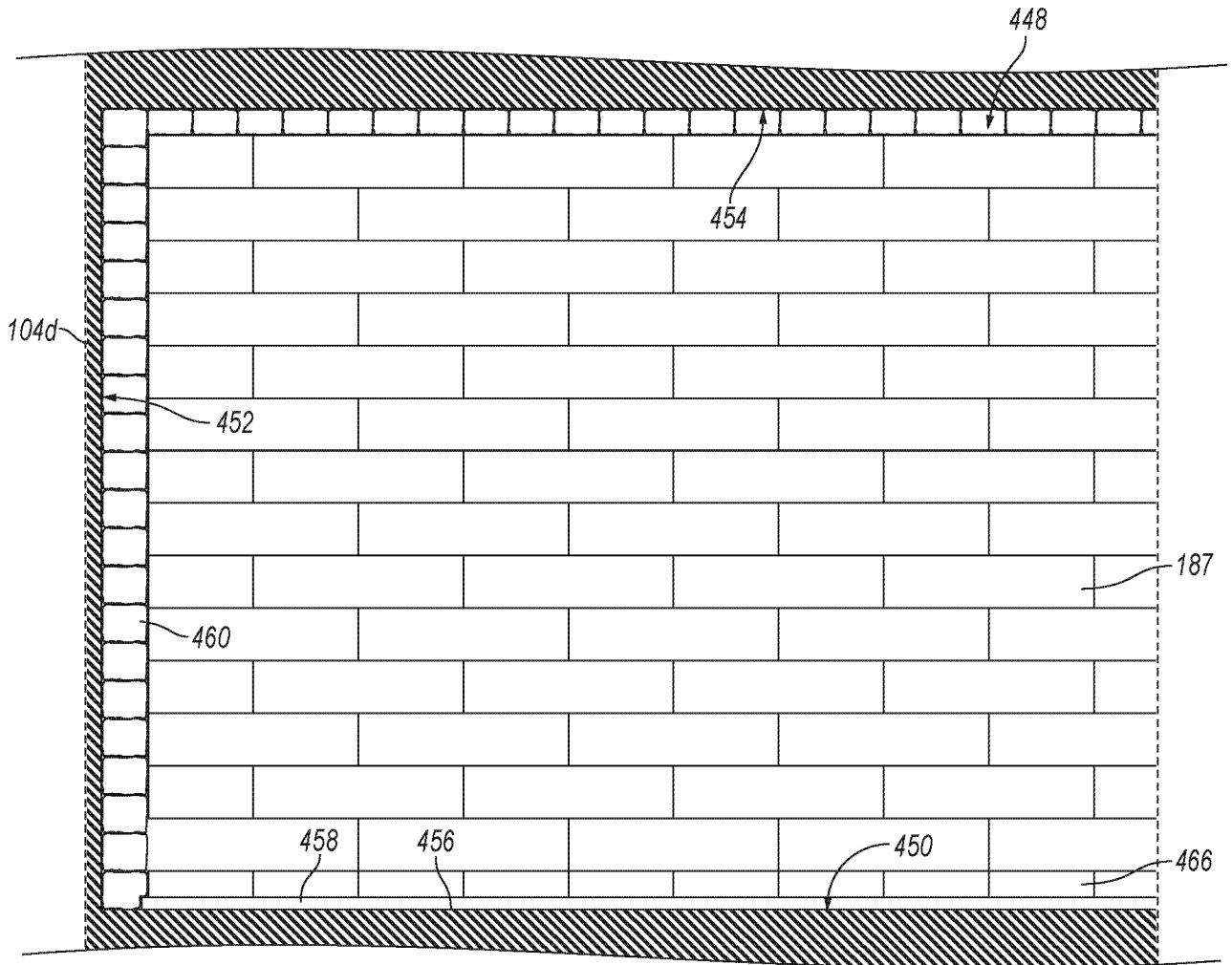

Fig. 6

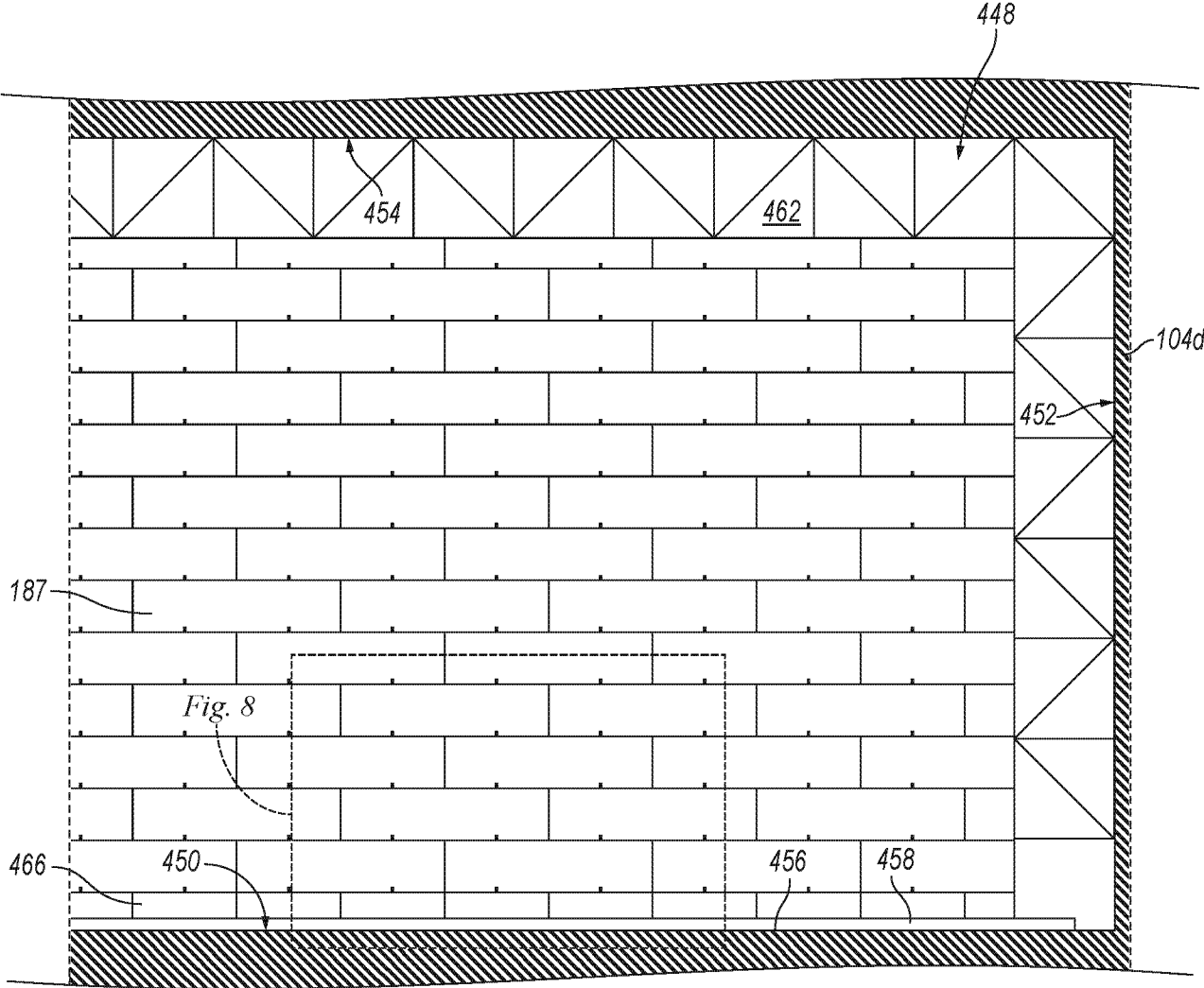

Fig. 7

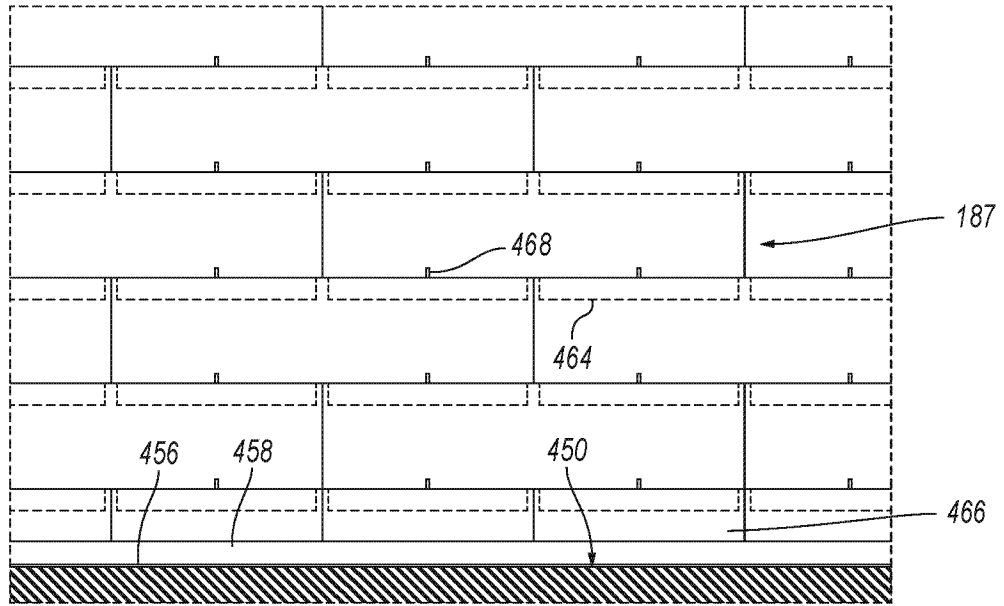

Fig. 8

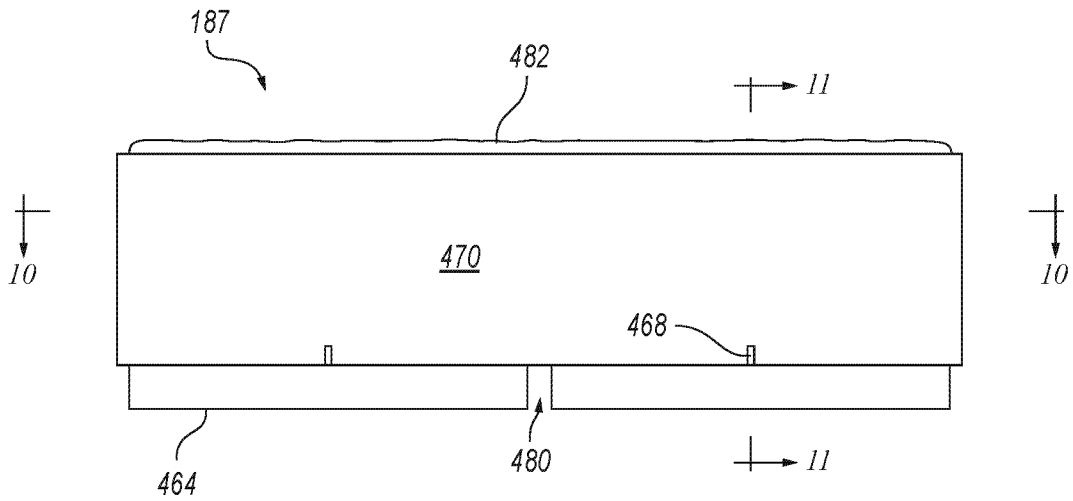

Fig. 9

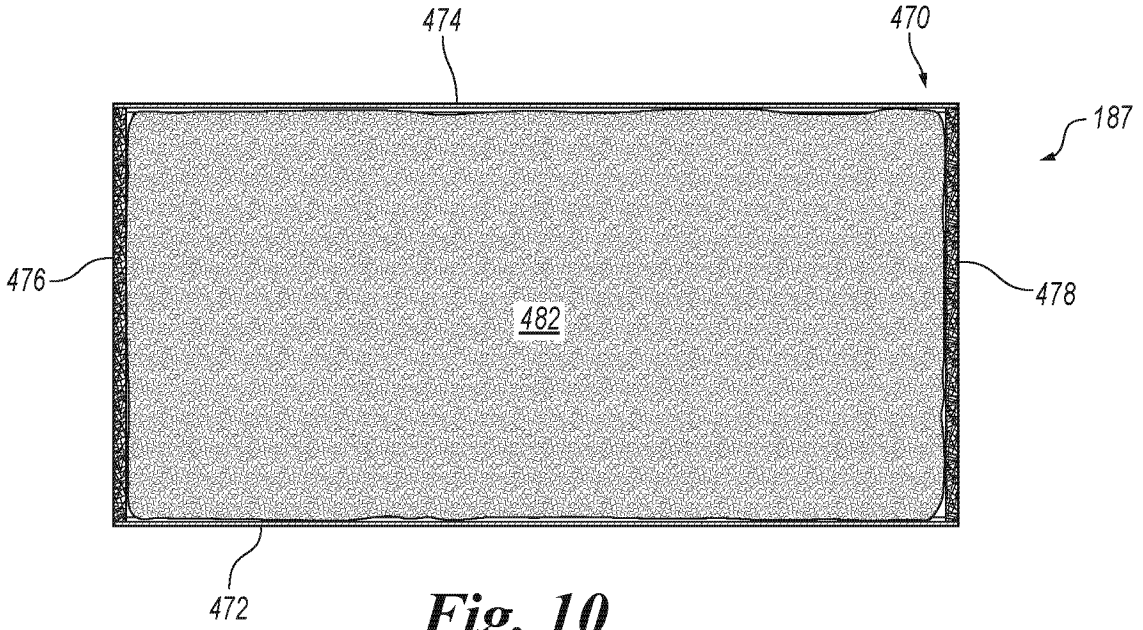

Fig. 10

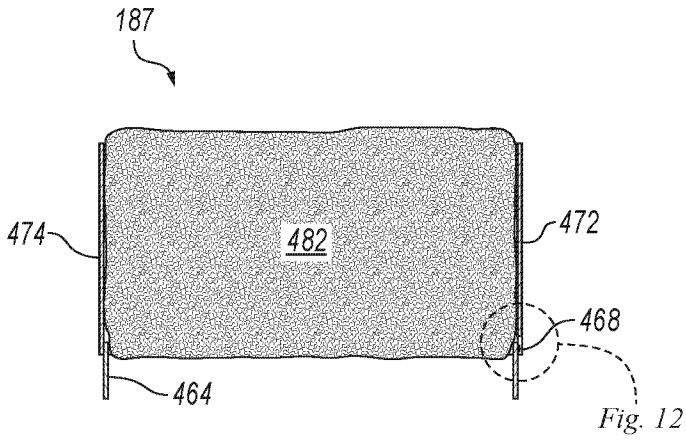

Fig. 11

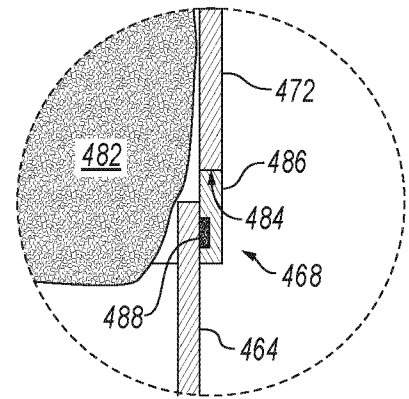

Fig. 12

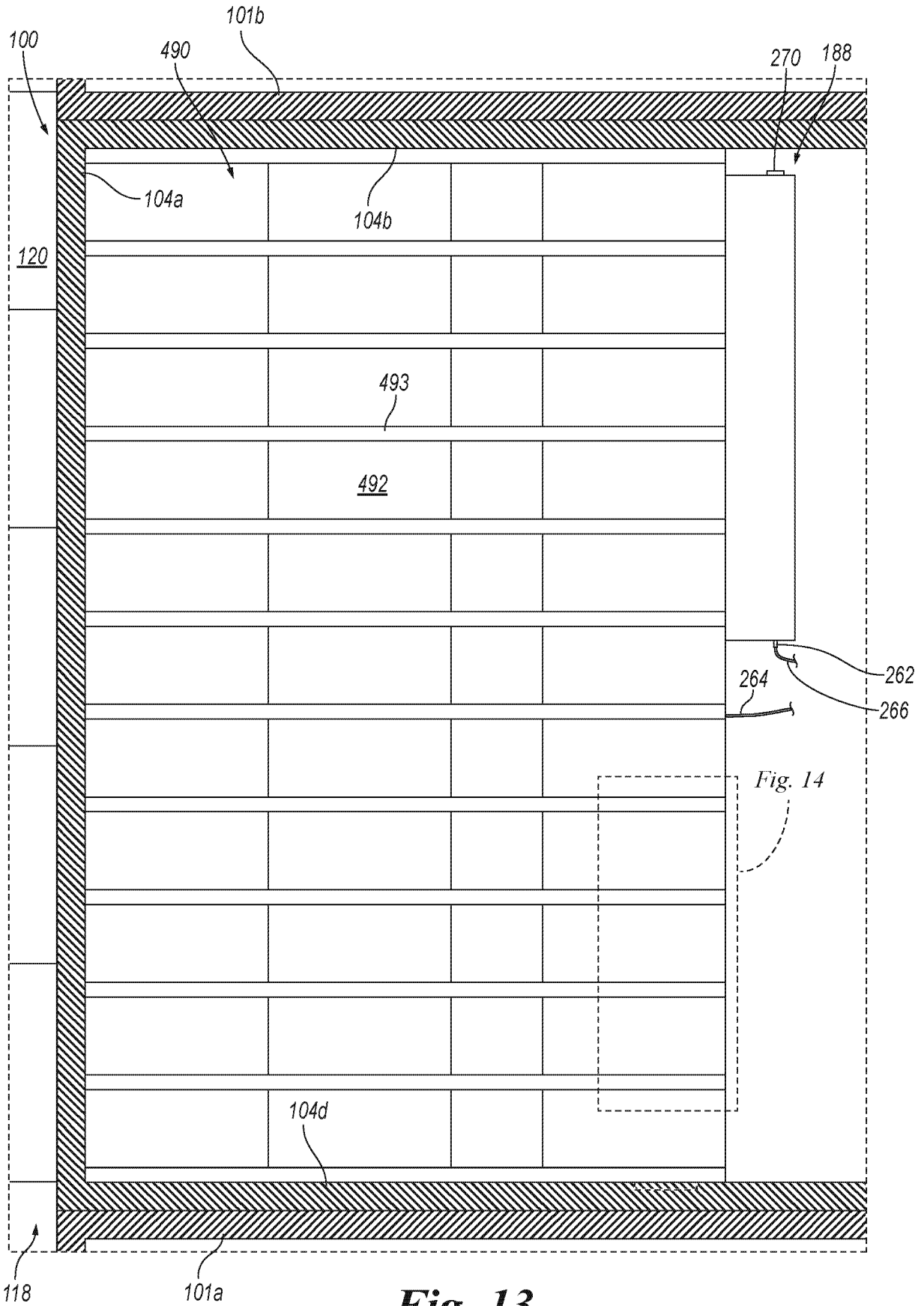

Fig. 13

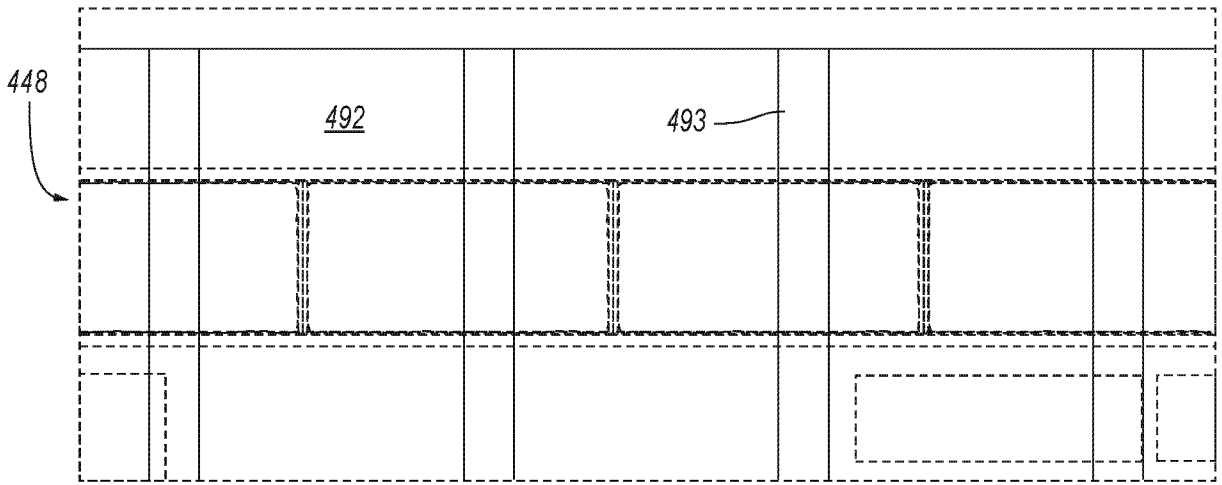

Fig. 14

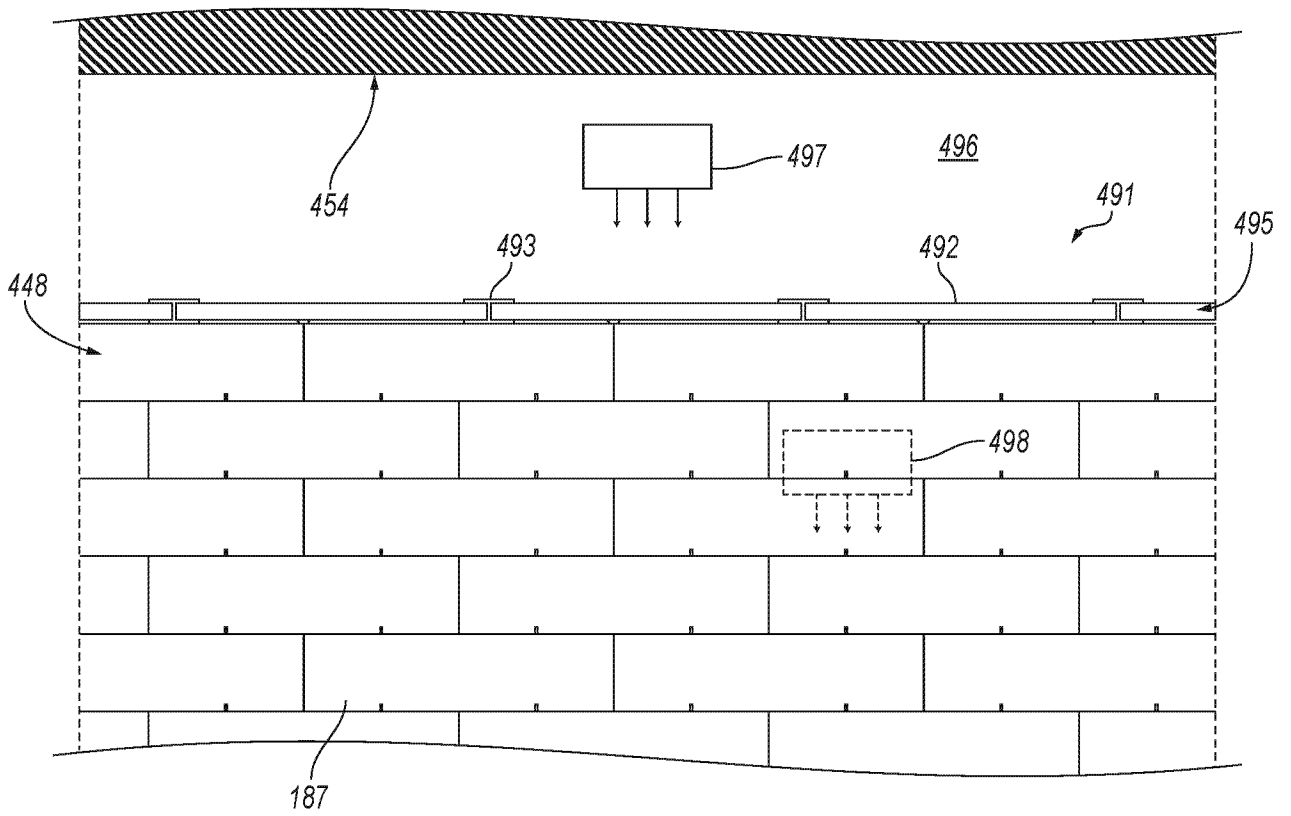

Fig. 15

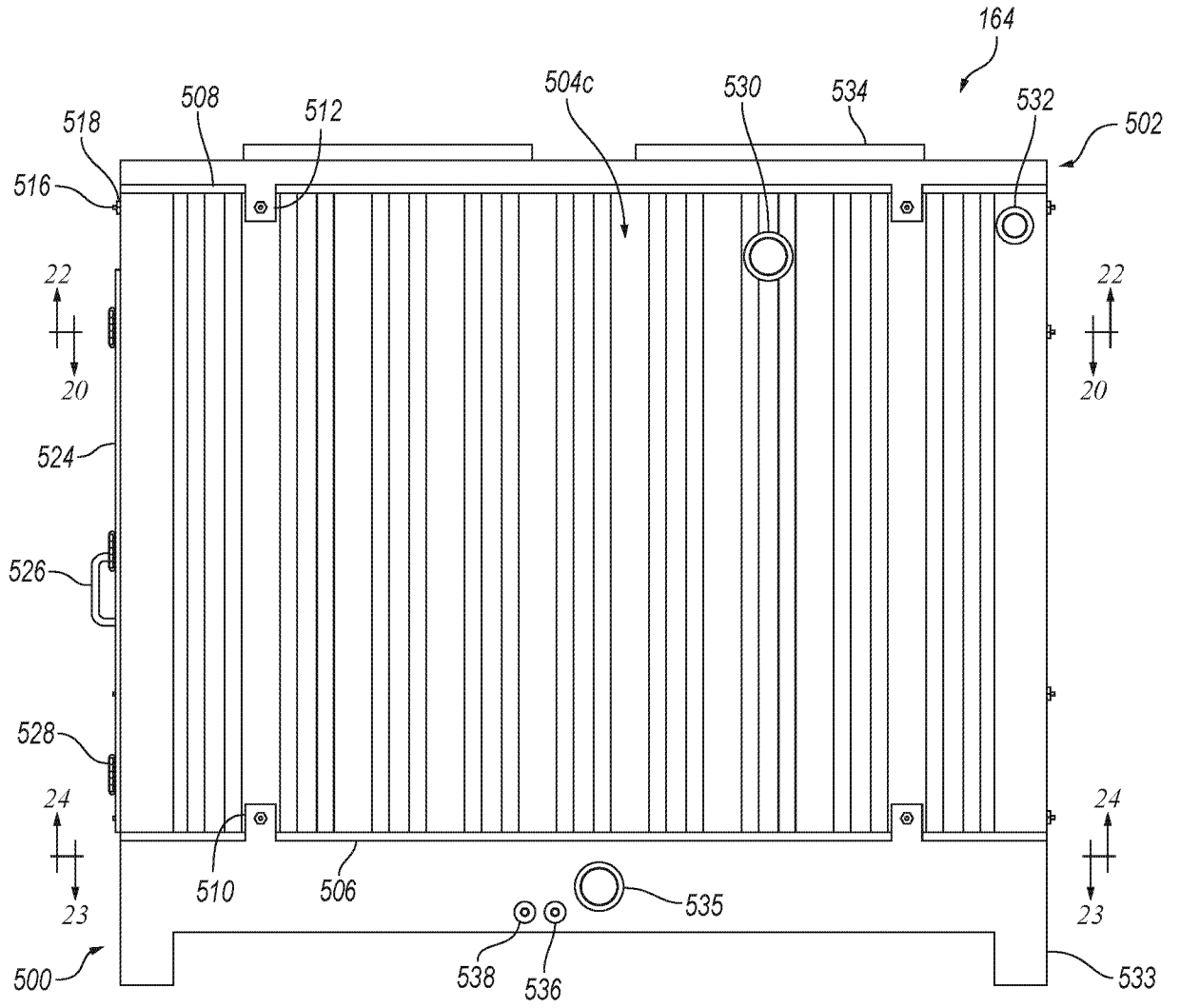

Fig. 16

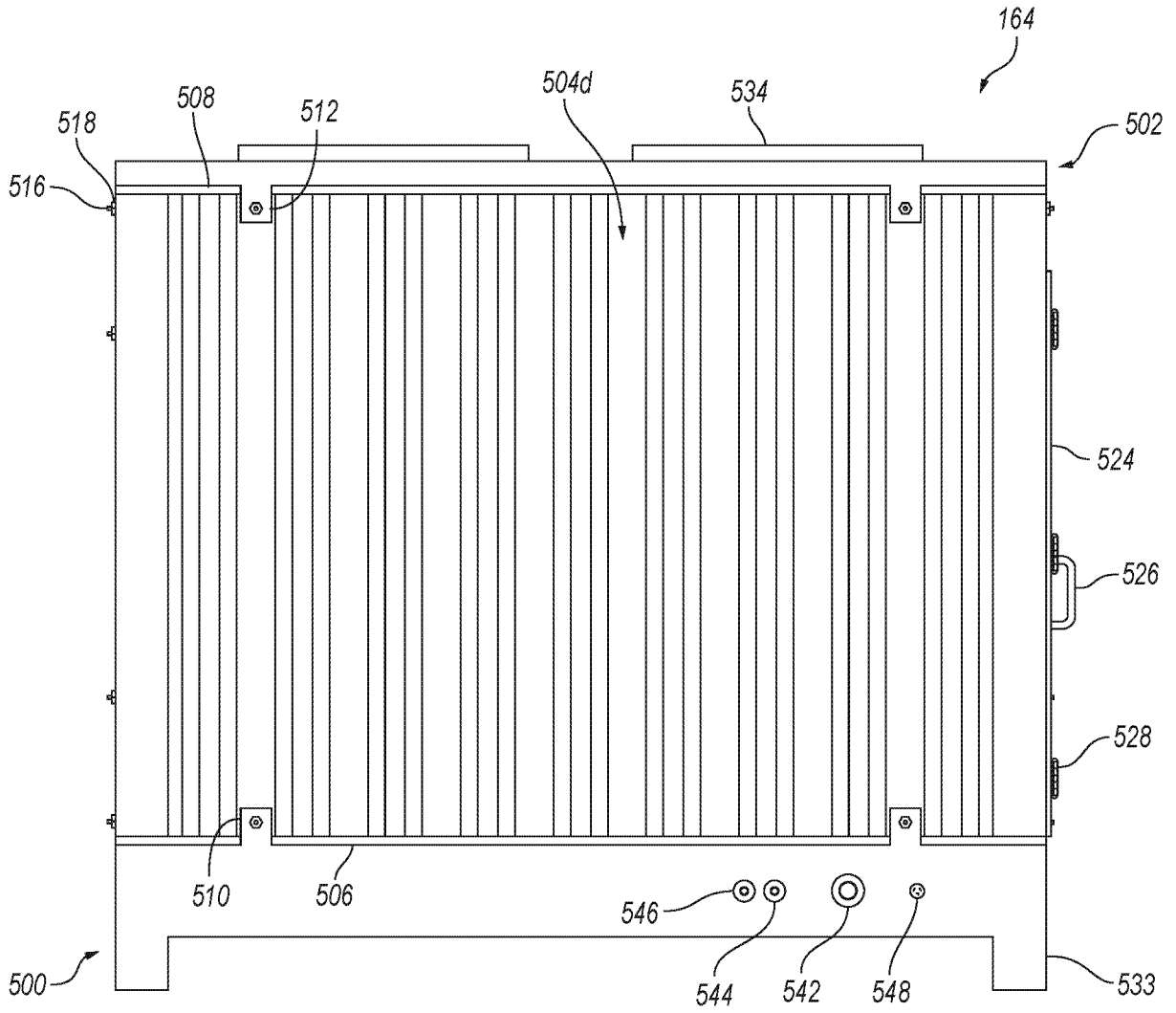

Fig. 17

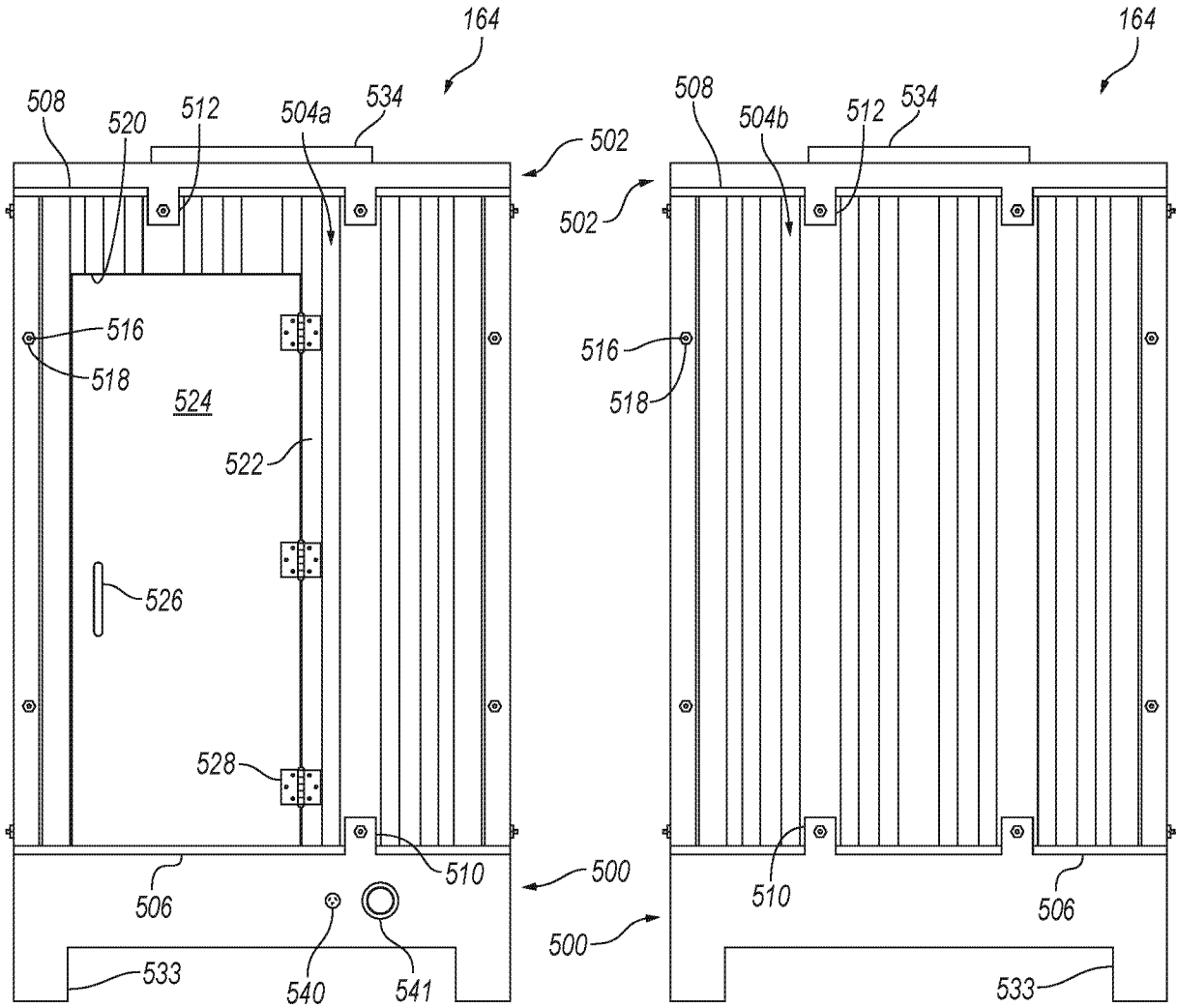
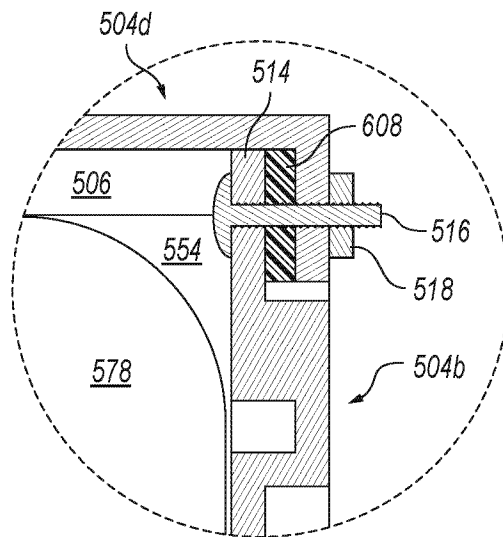
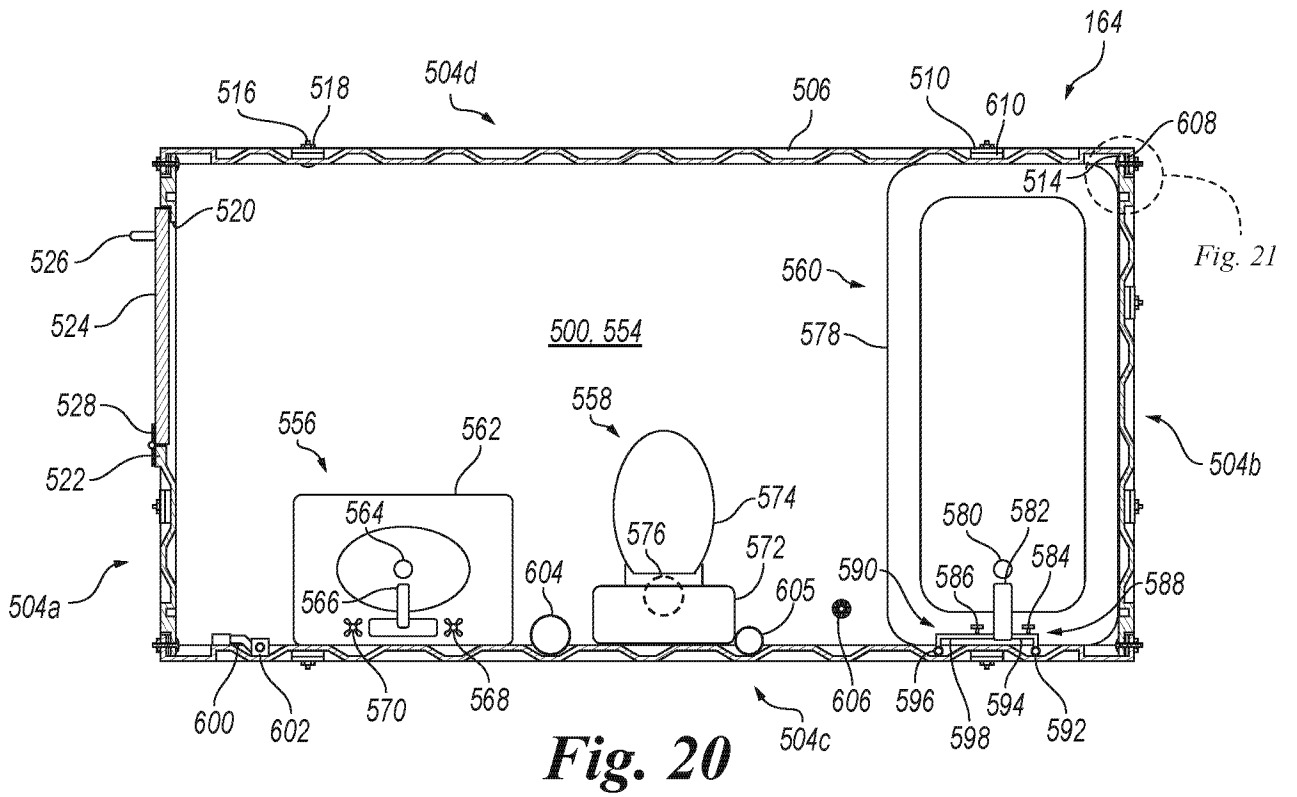

Fig. 18

Fig. 19



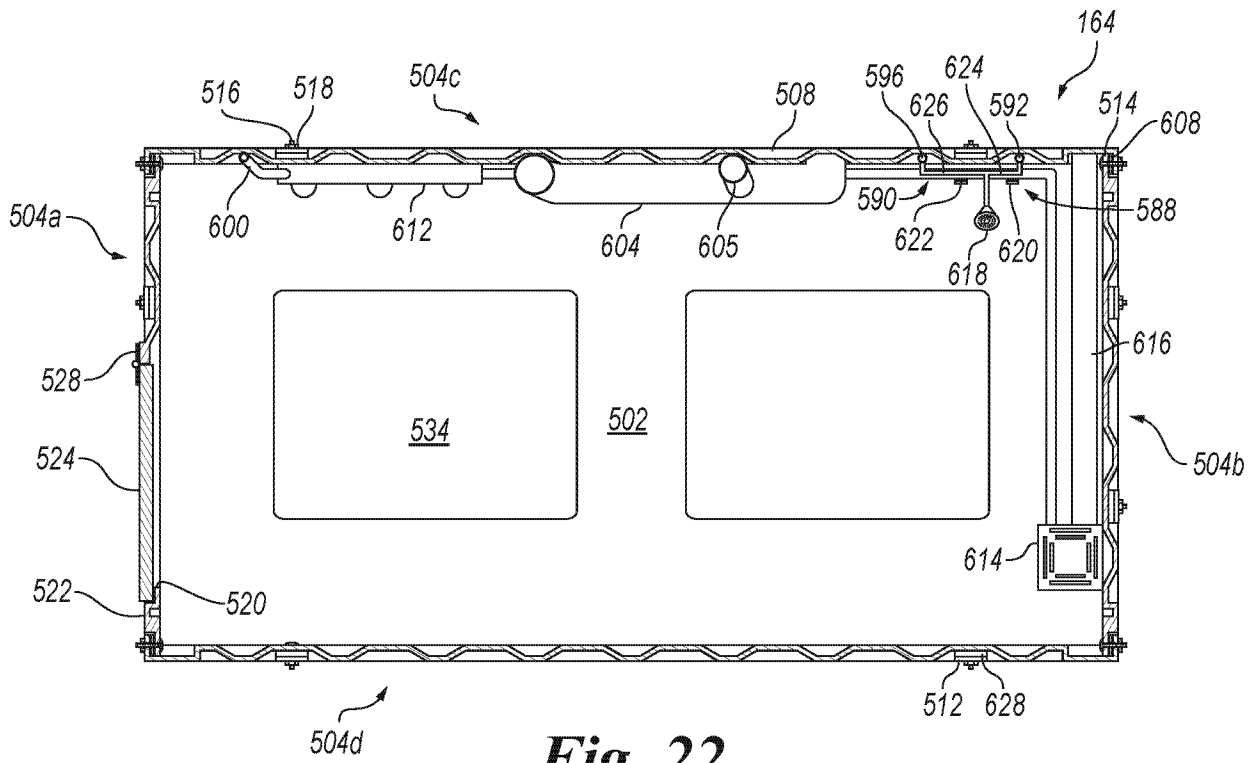

Fig. 22

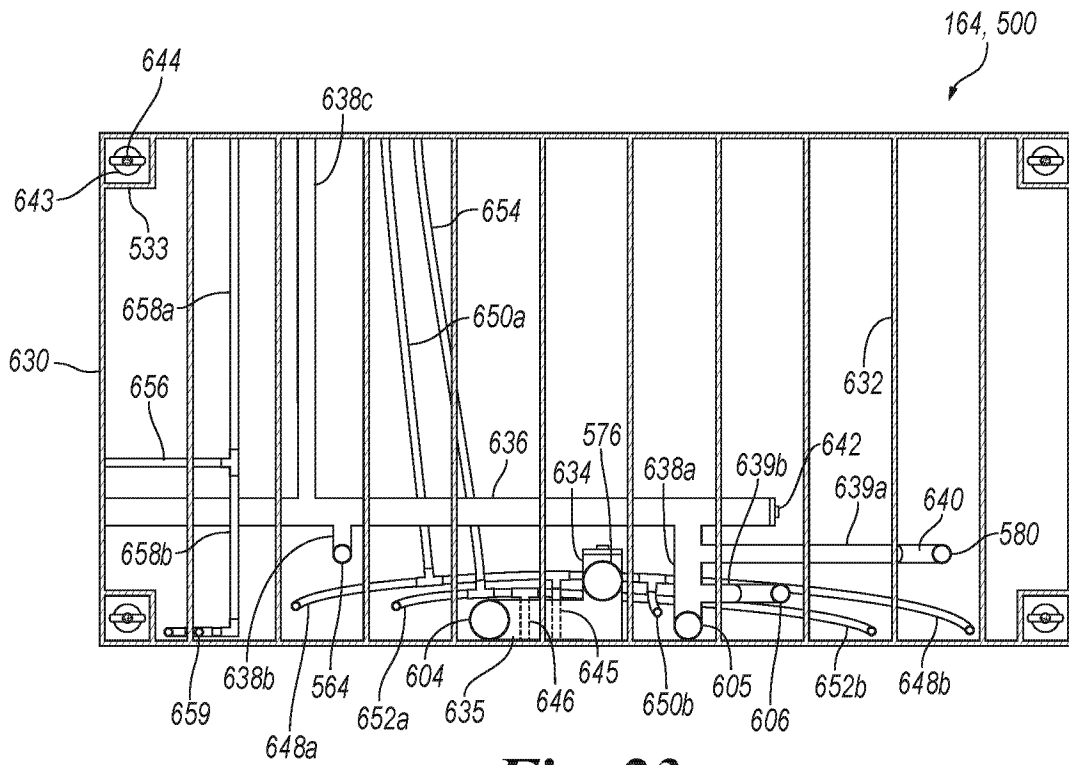

Fig. 23

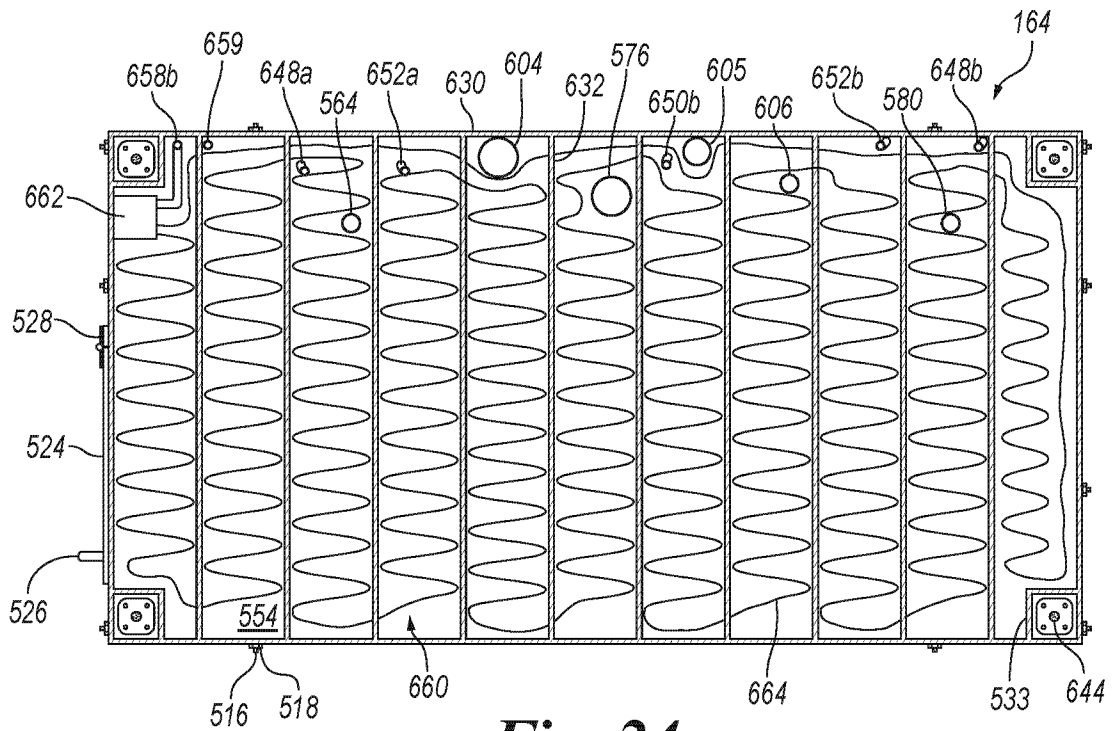

Fig. 24

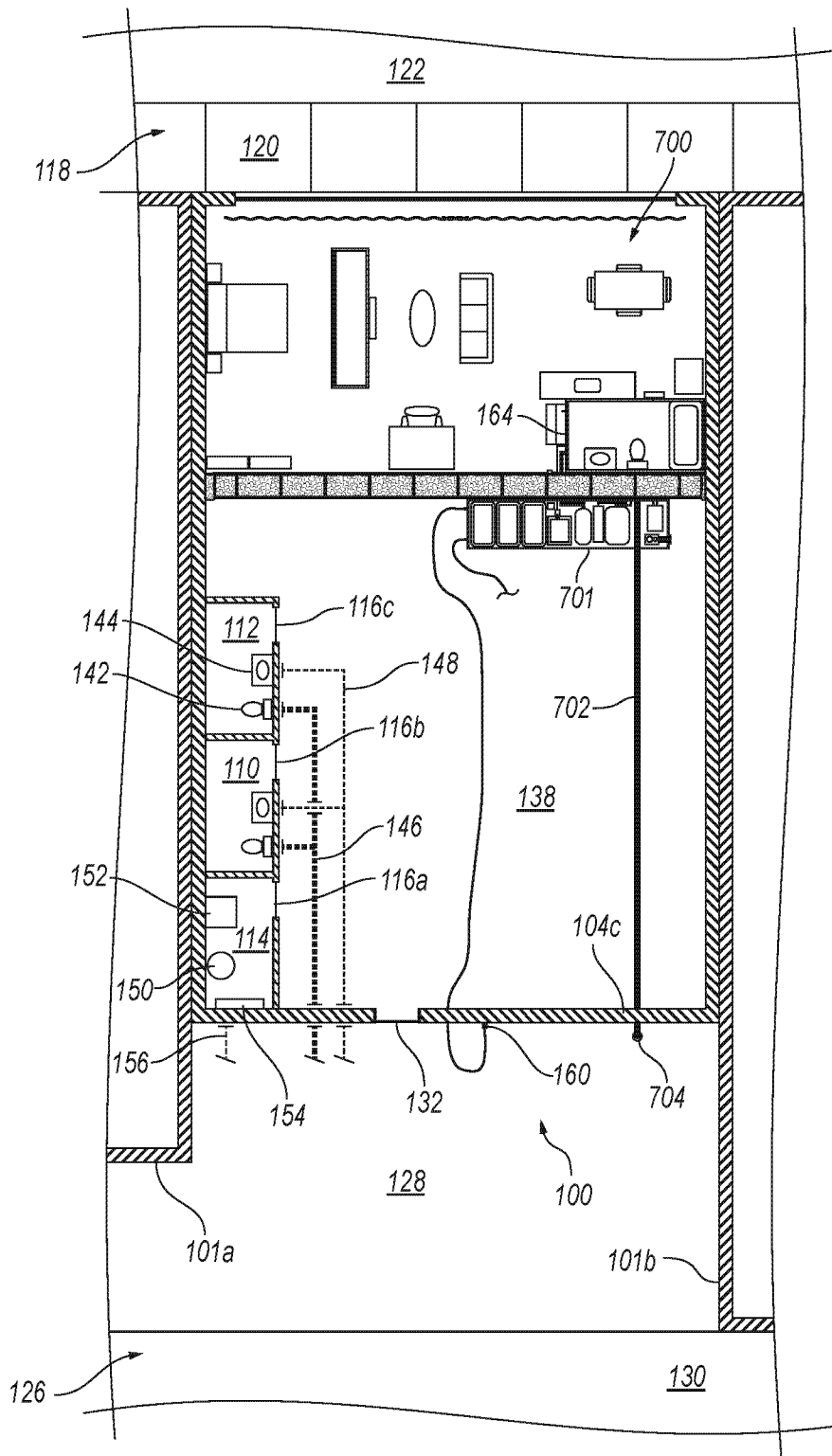

Fig. 25

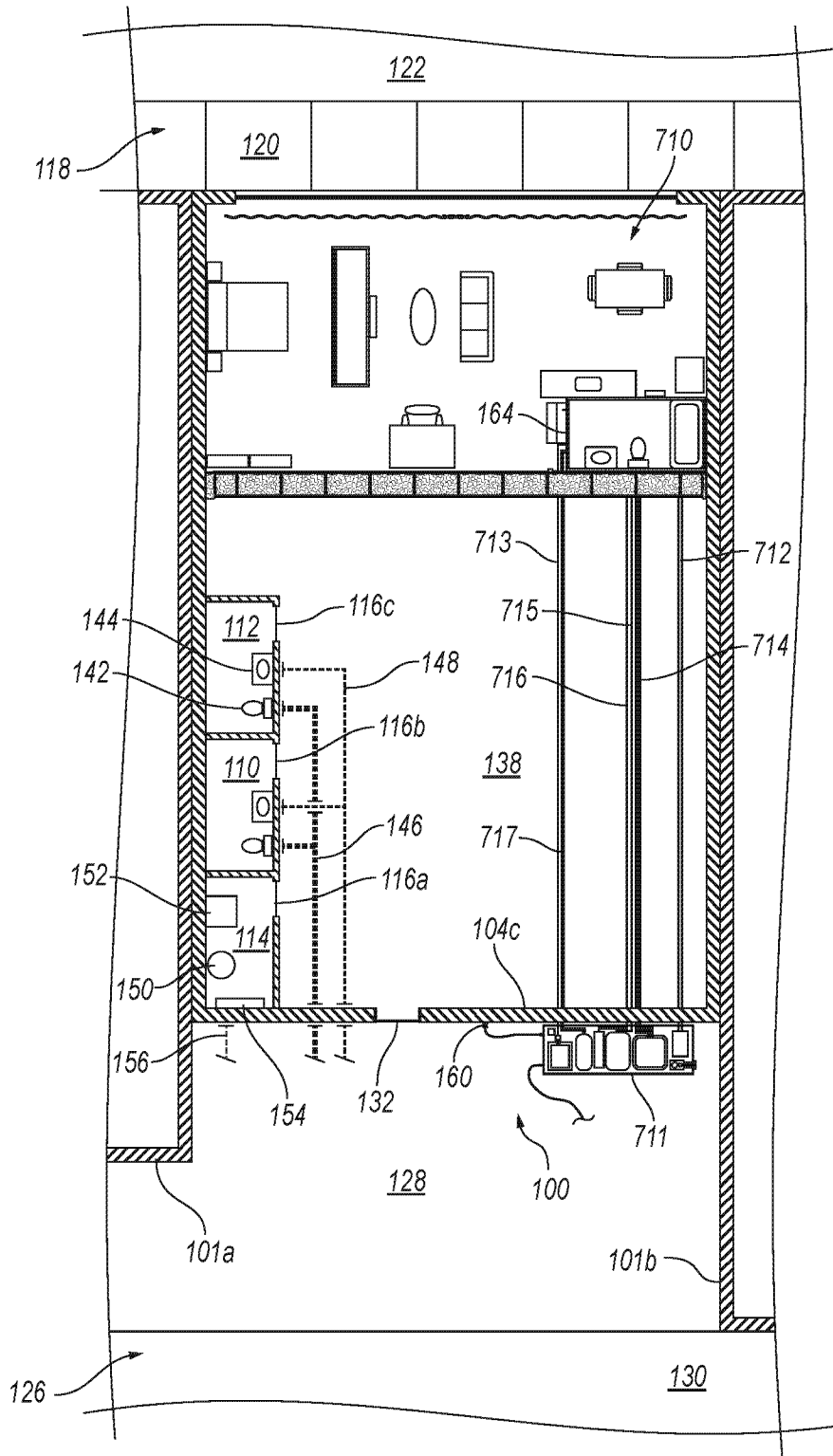

Fig. 26

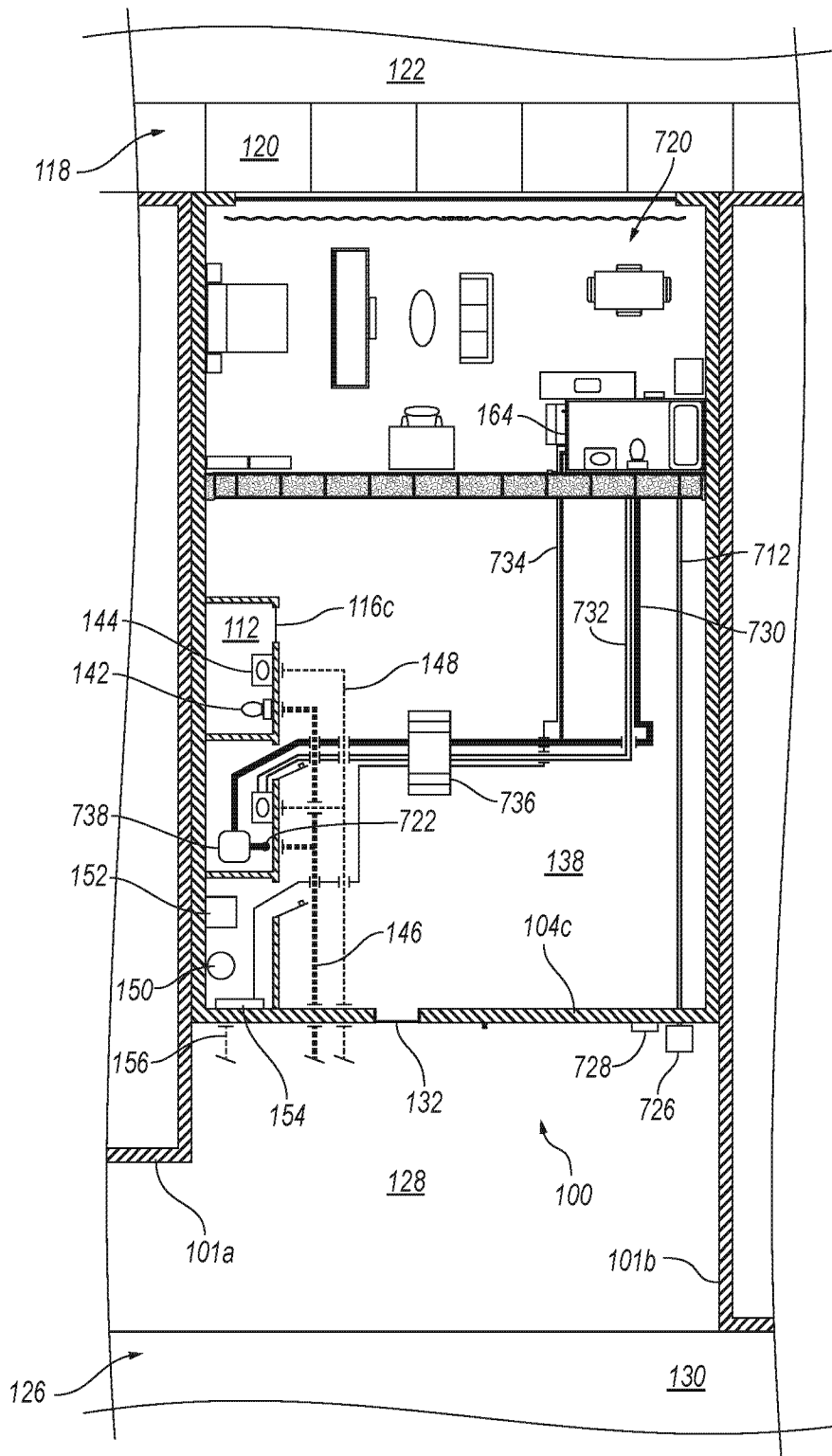

Fig. 27

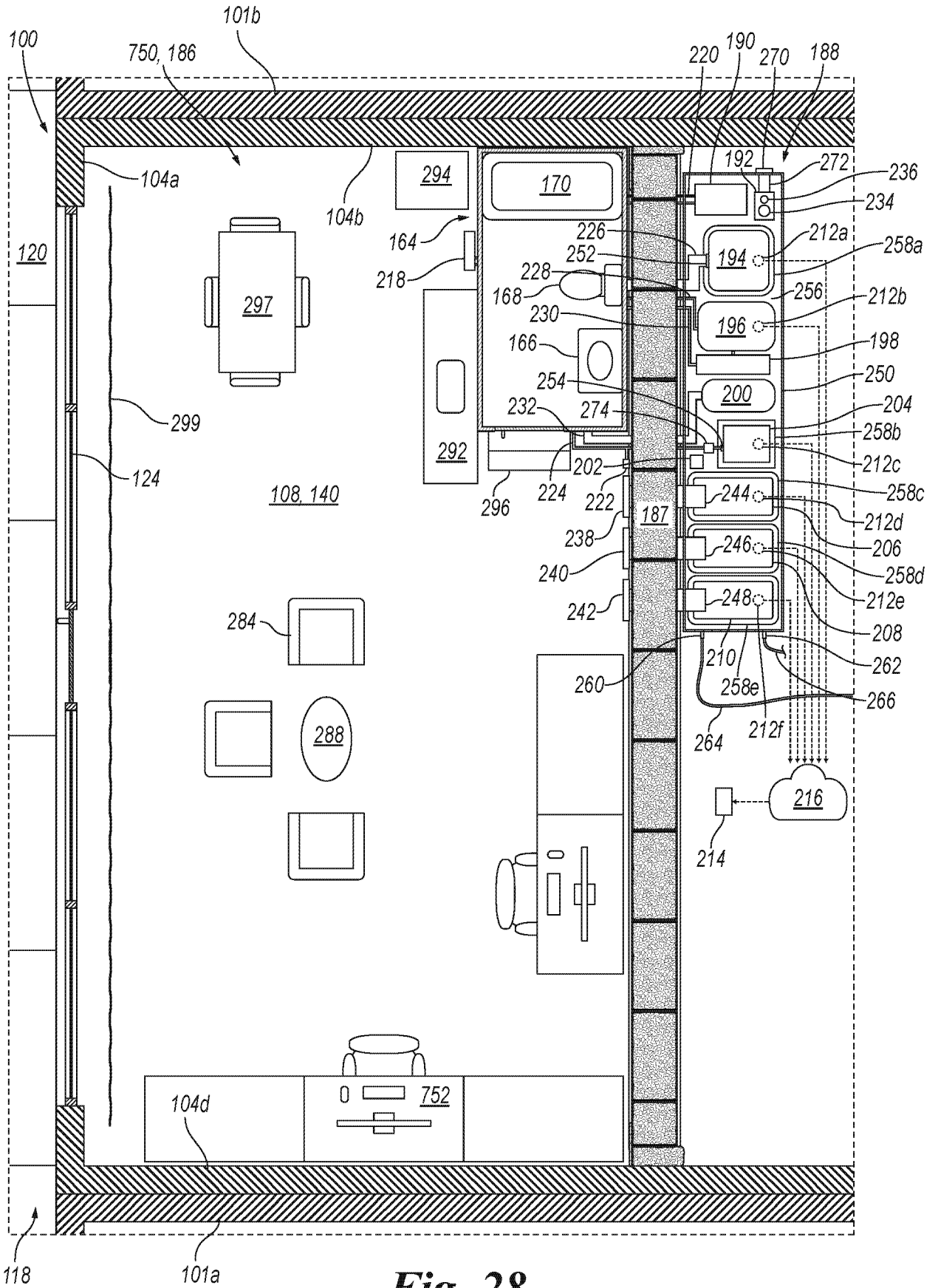

Fig. 28

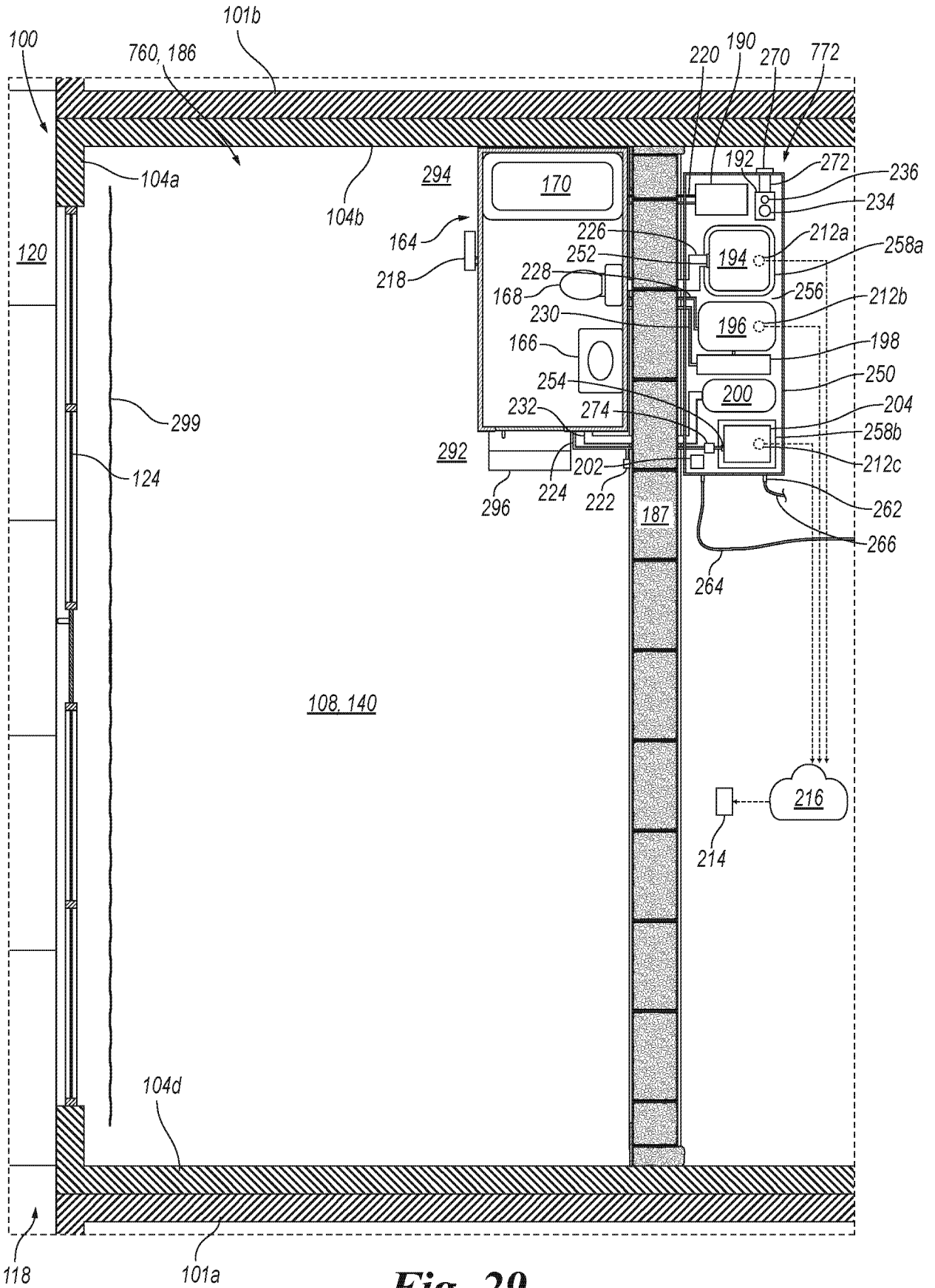

Fig. 29

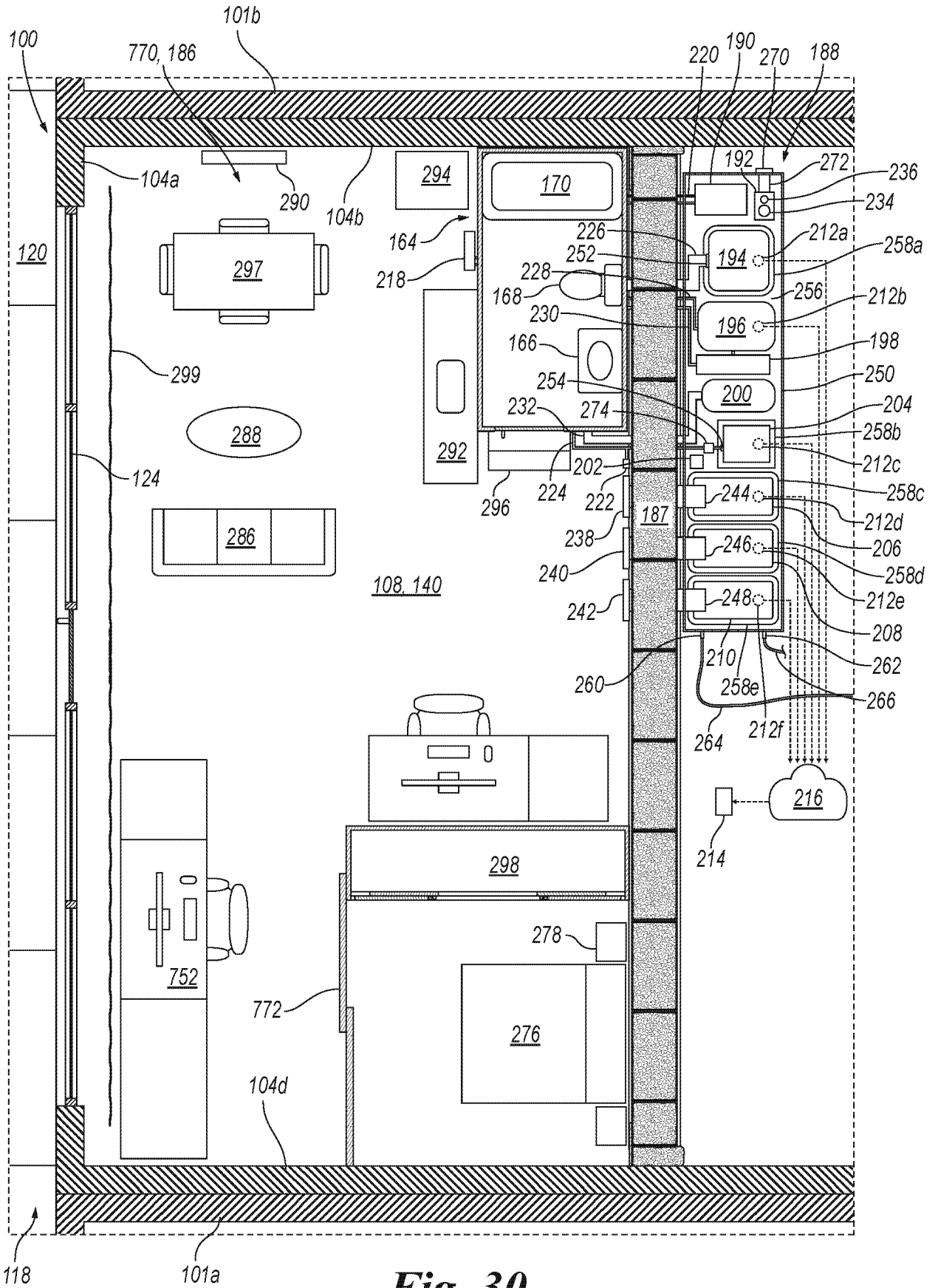

Fig. 30

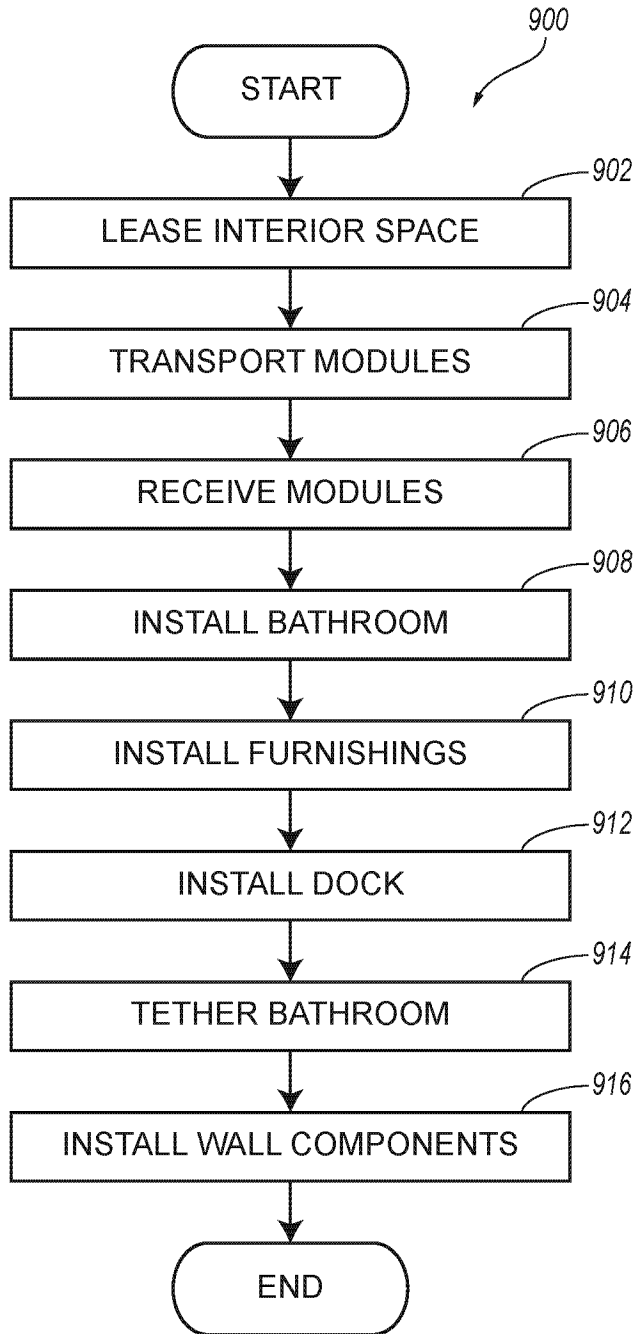

Fig. 31

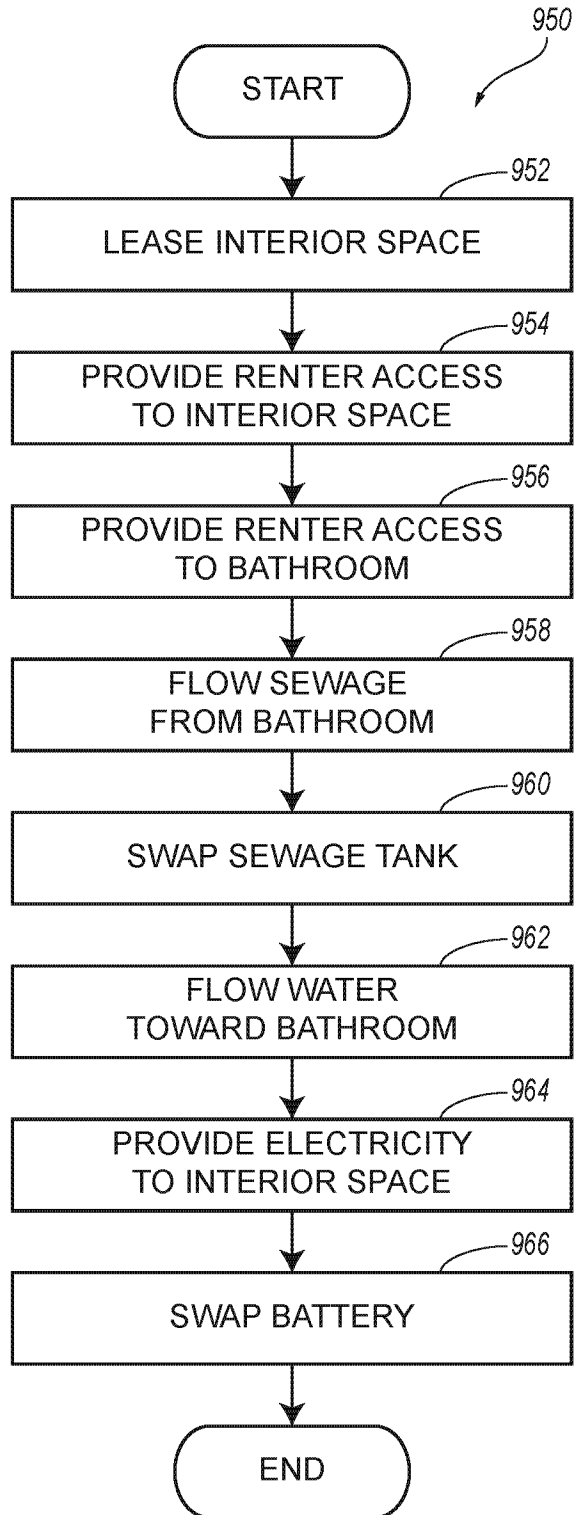

Fig. 32